

Mercy Corps

Evaluation and Assessment of Poverty and Conflict Interventions

Conflict & Economics: Lessons Learned on Measuring Impact



Photograph: Nathan Plowman/Mercy Corps

Abstract:

This case study is part of a USAID-funded research grant that examines the relationship between economic development and stability. In many parts of the world, Mercy Corps implements programs that combine economic development and peacebuilding. The *Evaluation and Assessment of Poverty and Conflict Interventions* project – implemented between July 2009 and December 2010 – had three main objectives: 1) to develop indicators and data collection tools that measure the impact of programs at the intersection of peacebuilding and economic development; 2) to field test these indicators and tools in three countries; and 3) to begin to assess several theories of change that inform Mercy Corps' programs. This report presents lessons learned about developing and using indicators and data collection tools to measure the impact of interventions designed to reduce both poverty and conflict. In addition, the document presents preliminary conclusions about the role of economic development programming in promoting peace.

Table of Contents

1. Executive Summary.....	4
2. Background.....	5
3. Methodology.....	7
4. Indicators	8
5. Data Collection Tools	11
6. Conclusions	17
Annex 8.1 Peace & Stability Indicator Menu.....	19
Annex 8.2 Economics & Conflict Indicator Menu.....	22
Annex 8.3 Ethiopia Survey.....	27
Annex 8.4 Uganda Survey.....	42
Annex 8.5 Indonesia Survey.....	52
Annex 8.6 Indonesia Disputes & Dispute Resolution	70
Annex 8.7 Indonesia Scored Community Relationship Mapping	74
Annex 8.8 Uganda/Ethiopia Conflict & Resource Mapping.....	80
Annex 8.9 Uganda/Ethiopia Scored Community Relationship Mapping.....	83
Annex 8.10 Uganda/Ethiopia Disputes & Dispute Resolution	90
Annex 8.11 Ethiopia Internal Actor Mapping.....	94
Annex 8.12 Violent Incident Reporting Form	97
Annex 8.13 Dispute Resolution Reporting Form.....	98
Annex 8.14 Selected References	99

Acknowledgements

This research project was made possible by a grant from USAID. The grant was a subcomponent of the ongoing QED-managed Knowledge Driven Microenterprise Development (KDMD) project. Mercy Corps was one of five organizations who received a USAID research grant to explore the relationship between poverty and conflict and to develop related indicators and data collection tools. Other grantees included Banyan Global, Land O Lakes International Development, the IRIS Center at the University of Maryland, and Columbia University. All five organizations worked together in the Poverty and Conflict Learning Network to share knowledge and experiences over the life of the research grants.

Jenny Vaughan was overall lead for the research project and authored the Uganda case study and the Lessons Learned overview. Jennifer Graham authored the Indonesia case study. Both received contributions from Sharon Morris, Rebecca Wolfe, Anna Young, Joe Dickman, Diane Johnson, Lisa Inks, Vanessa Corlazzoli, Elizabeth Sullivan, and Colin Christensen. Special thanks to the field teams in Uganda, Ethiopia, and Indonesia whose collaboration in tool development and data collection was critical to the success of the project, including Mesfin Getaneh, Solomon Tsegaye, Rebecca Girma, Endrais Hezana, Tirame Godebo, Bereket Akele, Tedla Bekele, Mahlet Seifu, Olga Petryniak, Fasil Demeke, Simon O’Connell, Sam Koroma, Cyprian Kaziba, Darius Radcliffe, Andrew Simbwa, George Opiyo, Stella Lokel, Malka Older, Elpido Meido, Siti Fitri Natsir, Florindo Michael Bell, Renssy Sohilit, and Nurhanna Alwahiit Castella.

Acronyms

BBP	Building Bridges to Peace
CRM	Conflict and Resource Mapping
EAPC	Evaluation and Assessment of Poverty and Conflict Interventions
FGD	Focus Group Discussion
KDMD	Knowledge Driven Microenterprise Development
M&E	Monitoring and Evaluation
MERP II	Maluku Economic Recovery Program II
NGO	Non-Governmental Organization
SCRM	Scored Community Relationship Mapping
UPDF	Uganda People’s Defense Force
USAID	United States Agency for International Development

1. Executive Summary

A significant body of knowledge exists on the relationship between poverty, conflict, and state failure. In his influential book *The Bottom Billion*, Paul Collier shows strong statistical support for the claim that conflict is clustered in the world's poorest nations. He also shows that unless economic growth takes place post-conflict, a nation has a 44% chance of slipping back into violence. Columbia scholar Macartan Humphreys confirms that as per capita GDP decreases, the probability of conflict increases.¹ Driven in part by these findings, donors and their partners are implementing increasing numbers of economic development programs in conflict and post-conflict environments, based on the assumption that these will contribute to both poverty reduction and conflict management.

To test this assumption and improve the quality of programming in conflict environments, USAID funded a series of research grants that explored the relationship between economic development, conflict, and state failure. The *Evaluation and Assessment of Poverty and Conflict Interventions* (EAPC) project is Mercy Corps' contribution to this larger research effort. Mercy Corps' research project had three key components. First, it articulated several hypotheses or theories of change that inform Mercy Corps' economic development and peacebuilding programs. These are:

1. If we build economic relationships across lines of division, then we will promote stability by demonstrating tangible, concrete benefits to cooperation.
2. If we strengthen livelihoods opportunities in high-risk regions and/or for high-risk populations, then we will promote stability by reducing competition for scarce economic resources.
3. If we use a community mobilization approach to economic development, then we will promote stability by encouraging community self-reliance and by building productive relationships to local government.

Second, the research team developed indicators and data collection tools that were specifically tailored to these theories of change. Third, the team ran field tests of these measures and tools in three Mercy Corps programs in Uganda, Ethiopia, and Indonesia to see if they could capture key relationships between economic variables and stability.

This document presents lessons learned about developing and using indicators and data collection tools to measure the impact of interventions designed to reduce both poverty and conflict. Recommendations include:

- Focus on a limited number of more precise, less nuanced questions in both survey and focus group data to simplify data analysis and minimize ambiguous results.
- Simplify participatory tools and surveys so that they take less time to administer, more interviews can be conducted, and sample size can increase.
- Favor forced choice questions in the survey instrument.
- While the development of indicators and data collection tools are crucial first steps in impact evaluation, they are not sufficient alone. The ability to measure impact depends on the design of the research methodology and particularly the use of control groups.

¹ For a good summary of recent research on the relationship between conflict and poverty, see Rice, Susan E., Corinne Graff, and Janet Lewis. "Poverty and Civil War: What Policymakers Need to Know." Working Paper #02, Global Economy and Development, The Brookings Institution, December 2006.

- Better tools are needed to assess underlying tensions and risk of future conflict in locations where there is an absence of overt violence.

In addition, the document presents preliminary conclusions about the role of economic development programming in promoting peace. Recommendations include:

- Economic development interventions should be designed to promote mutually beneficial cooperation rather than increasing competition between adversarial groups.
- Economic development interventions designed to promote peace should specifically target the underlying economic causes of conflict (e.g., natural resource competition) rather than aiming to increase general economic interactions between adversarial groups.
- “Deep” economic interactions (such as participation in economic associations or business partnerships) may build stronger relationships between adversarial groups and provide a stronger incentive for peace than “thin” economic interactions (such as trading at a local market).
- Trust-building measures may need to be implemented alongside or prior to economic development interventions in order to develop the relationships necessary for business partnerships and trade.

2. Background

Poverty is the single greatest risk factor for conflict. Research conducted over the past decade has demonstrated that low per capita income and slow economic growth drastically increase the chances that a country will experience violence and political instability.² Little is known, however, about the causal mechanisms that link poverty and conflict. Is poverty linked to conflict because deeply impoverished groups compete over scarce economic resources? Does poverty cause state failure by weakening the ability of state institutions to provide basic services and respond to threats? Does poverty cause violence because young men have no viable economic options other than joining an insurgency? In order to design effective, locally appropriate poverty alleviation and peacebuilding programs it is necessary to better understand the relationship between poverty and conflict.

As a relatively young discipline, the field of peacebuilding is still struggling to determine the best way to measure impact and identify success. A number of challenges have consistently hindered monitoring and evaluation (M&E) of peacebuilding programs. Chief among these is the lack of indicators for measuring impact across programs and contexts and the lack of tools for collecting data systematically and rigorously. This gap in measurement makes it difficult to identify which peacebuilding interventions are most effective, curtailing the advancement of the field. In order to evaluate the impact of peacebuilding and poverty alleviation programs in complex, conflict-affected environments and, ultimately, improve their effectiveness, the field requires development of meaningful indicators and practical data collection methods. Without these tools, programs may be replicating ineffective and potentially harmful practices and failing to scale up or adopt interventions that do work.

² Collier, Paul, and Anke Hoeffler. “Greed and Grievance in Civil War.” *Oxford Economic Papers*, 56, 2004; Fearon, James D., and David D. Laitin. “Ethnicity, Insurgency and Civil War.” *American Political Science Review* 91:1 (2003): 75-90.

Mercy Corps' *Evaluation and Assessment of Poverty and Conflict/Fragility Interventions* (EAPC) research project sought to address two key gaps that hinder the evaluation of economic development and peacebuilding interventions:

1. The lack of indicators and tools to evaluate program impact; and
2. The lack of knowledge about the causal relationships between poverty and conflict and the interventions that address these relationships most effectively.

Challenges of Monitoring and Evaluation in Peacebuilding

Monitoring and evaluation of peacebuilding programs presents specific challenges, which often inspire resistance from practitioners. While some challenges are more perceived than real, each of the following barriers should be considered when designing a monitoring and evaluation strategy for peacebuilding programs:

1. **Dynamic conflict context:** Because conflicts are often highly dynamic, adapting monitoring and evaluation practices to a changing context can be difficult to do quickly and in a way that provides transferable learning.
2. **Limited theoretical foundation:** In the relatively new field of peacebuilding, there are currently few, if any, agreed upon theories or strategies for building and sustaining peace.
3. **Lack of impact indicators:** There is limited agreement about which indicators can be reliably measured in order to assess the impact of peacebuilding interventions and the extent to which these indicators apply across contexts.
4. **Measuring intangible change:** Central aspects of peacebuilding, such as changes in trust and relationships, can be difficult to detect and quantify.
5. **Overlap of development and peacebuilding:** Because good peacebuilding practices and sustainable development strategies often manifest in similar activities and stem from similar theories of change, distinguishing the two is difficult in monitoring and evaluation.
6. **Attribution:** So many factors affect peace and conflict that attributing a particular change to a specific activity or strategy is extremely difficult. This challenge is common to other development fields. However, because the field of peace and conflict is still new and causes of peace and conflict are still not well understood, attribution is especially difficult to accurately assess in peacebuilding programs.
7. **Measuring prevention:** Much of measuring peacebuilding success relies on the counterfactual – how can you know whether violence would have been made better or worse without the intervention?
8. **Ethical constraints:** Employing rigorous evaluation methods, such as random sampling and control trials, is often considered unethical in cases where people's security is at stake.

For more information:

- *Designing for Results: Integrating Monitoring and Evaluation in Conflict Transformation Programs*. Cheyanne Church and Mark M. Rogers. Search for Common Ground, 2006. http://www.sfcg.org/programmes/ilr/ilt_manualpage.html
- *Reflective Peacebuilding: A Planning, Monitoring and Learning Toolkit*. Hal Culbertson, John Paul Lederach, and Reina Neufeldt. The Joan B. Kroc Institute for International Peace Studies and Catholic Relief Services, Southeast East Asia Regional Office, 2007. http://www.nd.edu/~krocinst/documents/crs_reflective_final.pdf
- *Guidance on Evaluating Conflict Prevention and Peacebuilding Activities: Working Draft for Application Period*. OECD Development Assistance Committee, 2008. http://www.oecd.org/secure/pdfDocument/0,2834,en_21571361_34047972_39774574_1_1_1_1,00.pdf

Goals of the Study

Mercy Corps' *Evaluation and Assessment of Poverty and Conflict Interventions* (EAPC) research project aimed to strengthen Mercy Corps' effectiveness in evaluating the impact of programs that seek to reduce both poverty and conflict. In particular, this research aimed to:

1. Develop adaptable and meaningful indicators for economic development and peacebuilding interventions;
2. Develop and field test a variety of data collection tools, including surveys, participatory assessment tools, and monitoring forms; and
3. Test several theories of change that underlie many of Mercy Corps' integrated economic development and peacebuilding programs.

Mercy Corps' integrated economic development and peacebuilding programs are based upon several theories of change that link economic development activities to stability outcomes through a variety of causal mechanisms. EAPC aimed to develop indicators and tools to test three specific theories of change, including:

1. If we build economic relationships across lines of division, then we will promote stability by demonstrating tangible, concrete benefits to cooperation.
2. If we strengthen or diversify livelihoods opportunities in high-risk regions and/or for high-risk populations, then we will promote stability by reducing competition for scarce economic resources.
3. If we use a community mobilization approach to economic development, then we will promote stability by encouraging community self-reliance and by building productive relationships to local government.

Definition

“A **theory of change** is an explanation of how and why a set of activities will bring about the changes the project's designers seek to achieve.”

– *Reflective Peacebuilding*

3. Methodology

The research project, implemented from July 2009 to December 2010, built on Mercy Corps' strengths as a practitioner organization and sought to increase the rigor of program monitoring and evaluation systems by integrating research practices from the academic community.

Three Comparative Case Studies

Three Mercy Corps field programs participated in the research project: *Strengthening Institutions for Peace and Development* (SIPED) in Ethiopia, *Building Bridges to Peace* (BBP) in Uganda, and the *Maluku Economic Recovery Program II* (MERP II) in Indonesia. These programs were selected because they explicitly aim to promote peace through economic development activities and thus provided the opportunity to evaluate the impact of interventions designed to reduce both poverty and conflict. Other selection criteria included buy-in from the country-based field teams and feasible timing.

Integrating Research into Ongoing Monitoring and Evaluation Activities

Research activities were mainstreamed into the participating field programs' M&E systems, so that data was generated in the course of regular M&E activities. Indicators and tools were developed by the headquarters-based research team and then field tested and revised in collaboration with field staff. Field staff also served as the primary managers of data collection. This approach had several distinct advantages, including building staff capacity, ensuring the practical relevance of indicators and tools, strengthening M&E of participating programs, and leveraging field program resources for

Case Study Field Programs

Ethiopia: Strengthening Institutions for Peace and Development

Peace and development are interconnected challenges in Ethiopia, where many communities face cycles of violence and poverty. Competition among local groups is on the rise as populations grow, resources shrink, and climate change takes effect. At the same time, weapons proliferation, identity politics, and weakening local governance structures are limiting the abilities of traditional dispute resolution mechanisms to resolve conflicts. With support from USAID, Mercy Corps has been working since 2004 with local institutions and leaders to build conflict management capacity and alleviate tensions through a blend of peacebuilding and livelihoods activities. These activities aim to support local development processes that promote collaborative partnerships and build trust and understanding between groups.

Indonesia: Maluku Economic Recovery Program II

In 1999, the Maluku region of Indonesia was torn apart by communal violence, displacing 500,000 people and leading to economic collapse. Today, Maluku is on its way to normalization, and economic recovery is materializing in many conflict-affected communities. Rebuilding relationships across lines of division is becoming a priority for individuals seeking to restore access to trade and transportation. Since 2000, Mercy Corps has provided economic recovery and peacebuilding assistance throughout Maluku. Funded by New Zealand Aid, the current program integrates economic and peacebuilding initiatives to improve economic well-being, support reintegration, and address key causes of conflict. Activities include supporting community-based livelihood groups, providing technical assistance to strengthen livelihoods, and supporting peaceful dispute resolution.

Uganda: Building Bridges for Peace

For decades, conflict and poverty have plagued northeast Uganda's Karamoja region. Groups competing for increasingly scarce resources often resort to cattle raiding, ambushes, and theft, exacerbating an atmosphere of fear and mistrust, and discouraging development. Mercy Corps' Building Bridges to Peace program addresses the root causes of conflict in Karamoja by forging economic relationships between communities in conflict. The three-pronged approach includes strengthening local mechanisms for conflict mitigation; supporting reconciliation through dialogue, trust-building, and joint monitoring; and building cooperation through joint livelihoods projects, including construction of a dam, joint farming, and rehabilitation of local roads and markets.

the research project. Constraints associated with this approach included differing priorities between the research team and the field teams and limited human and financial resources, which required compromise and curbed the ability of the research team to independently drive the research agenda.

Mixed Methods

Mercy Corps employed a combination of quantitative and qualitative data collection tools, including surveys, monitoring forms, and participatory assessment tools. These tools were intended to complement each other by generating generalizable, numeric data as well as contextual information that could help to explain processes and trends. This also allowed the research team to test a variety of ways for collecting similar data in order to determine the most effective method. The main drawbacks of this approach included the increased amount of time required for data collection and analysis and the difficulty of comparing findings from multiple methodologies spanning different population samples.

4. Indicators

In the peacebuilding field, the development of impact indicators has been limited by two key challenges. First, many practitioners have argued that it is impossible to measure peacebuilding outcomes because so many of these outcomes are intangible. Concepts such as changes in relationships between conflicting communities, perceptions of the "other," and trust are difficult to

define and quantify, and practitioners have been reluctant to impose definitions that are determined by outsiders and fail to capture locally relevant concepts. Second, many practitioners have asserted that it is not feasible to develop a set of universal indicators that permit comparison of peacebuilding impacts across programs and locations, arguing that conflict situations and the interventions designed to address them are so context-specific that they defy comparison. While these constraints pose genuine challenges to the assessment of peacebuilding outcomes, they are not insurmountable.

Definition:

“An **indicator** is a quantitative or qualitative factor or variable that provides a simple and reliable means to reflect the changes connected to an intervention.”

- *Designing for Results*

Mercy Corps sought to address these challenges by developing and field testing a set of common indicators to capture the expected outcomes of three integrated economic development and peacebuilding programs in three countries. Particular effort was made to develop indicators that measure not just the final expected outcome but key steps in the causal chains outlined by Mercy Corps’ theories of change. A range of indicators were developed to measure both behavior and attitudinal components of the same concept.

Over the course of the project, researchers developed two separate indicator menus (see Annex 8.1 and 8.2), both of which are comprised of impact indicators that describe changes in behaviors and attitudes, including:

1. A menu of *peace and stability indicators*. These indicators are focused on three dimensions of peacebuilding outcomes, including changes in security, relationships between conflicting communities, and dispute resolution capacity.
2. A menu of *economics and conflict indicators*. These indicators are focused on outcomes of relevance to the relationship between poverty and conflict described by Mercy Corps’ theories of change, including changes in economic interactions between conflicting communities and access to resources.

Measuring Trust

Trust between conflicting communities is critical to rebuilding and maintaining peace. This intangible concept, however, is difficult to quantify, and community members may not be willing to share their feelings of the conflicting community honestly. In order to try to capture this concept, Mercy Corps developed two different types of survey questions. One question asked explicitly about feelings of trust:

- Do you trust people from [conflicting community]? *Never, Rarely, Sometimes, Most of the time, Always*

Another set of questions tried to avoid conscious biases by probing feelings of trust indirectly:

- In regards to someone from [conflicting community], how comfortable would you feel...if your brother or sister married them?... starting a business with them?... if someone from that community was your leader?...paying them to watch your animals? *I am very comfortable with this, I am a little comfortable with this, I am neither comfortable nor uncomfortable, I am a little uncomfortable with this, I am very uncomfortable with this*

Additional analysis is necessary to determine the correlation between these different questions and to assess which type of question produces the most accurate and reliable results.

Indicator Development

The research team spent six months researching and developing indicators for use in the project. Indicators were drawn from a range of sources, including previous Mercy Corps programs, indicators employed by other practitioner organizations, and indicators developed in the academic community. Survey and focus group questions were created to capture each indicator, and in the process it became clear which indicators could be measured most effectively. In addition, the

Guidelines for Developing Indicators from Theories of Change

- **Identify the theories of change underlying the program.** Look at the goal, objectives, and activities outlined in the proposal and log frame. Explain how you think the activities will allow you to achieve the objectives and goal. Express this causal logic in an “if...then...” statement.
- **Prioritize the theories of change that you want to evaluate.** Roughly speaking, there should be one theory of change for each objective that explains how the activities will contribute to the achievement of that objective and how that objective will contribute to the achievement of the goal.
- **Map the causal pathway implicit in the theory of change.** This causal pathway should consist of 3-4 “steps” that explain how program activities lead to intermediate outcomes that in turn lead to a final outcome.
- **Brainstorm indicators for each step in the causal pathway.**
- **Evaluate and prioritize the list of brainstormed indicators.** Select 2-3 indicators for each step that you will measure.
- **Develop data collection tools for each indicator.** Ideally, one will be able to “triangulate” the data collected for each indicator by collecting data in several different ways.

Developing Indicators from Theories of Change in Indonesia

After participating in training on developing theories of change, field staff worked with a technical advisor from Mercy Corps’ conflict management team to identify the theories of change underlying Indonesia’s peacebuilding program. A tool drawn from the manual *Theory of Change: A Practical Tool for Action, Results, and Learning* was used to help the team articulate the theory of change in the form of a causal pathway, beginning with, “If we do ‘x’ intervention, then that will lead to ‘y’ actions/consequences, which will ultimately lead to the desired change.” For example, “*If we build economic and social relationships across lines of division, then people will believe they will incur economic losses if fighting breaks out and they will place a higher value on cooperation than conflict with former adversaries, and stability will increase.*” The team then brainstormed and selected indicators to measure each step of the causal chain. The team reviewed a number of possible data collection tools and selected a limited number based on the tools’ perceived effectiveness for measuring the selected indicators.

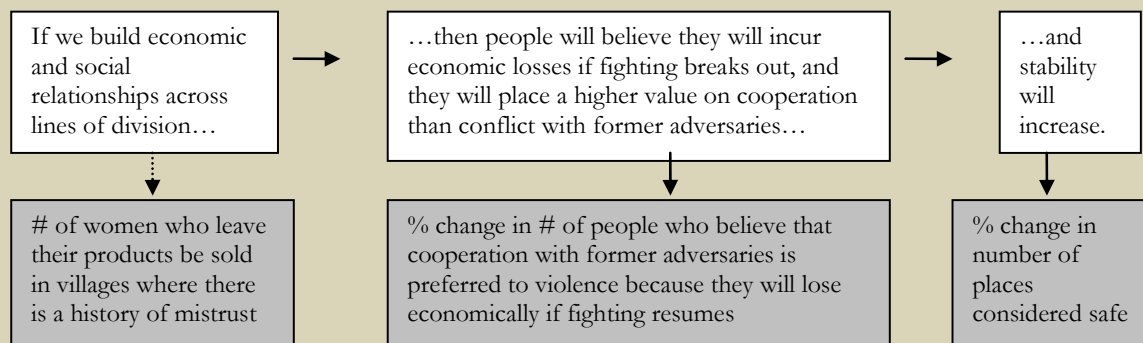

For more information:

- *Reflective Peacebuilding: A Planning, Monitoring and Learning Toolkit.* Hal Culbertson, John Paul Lederach, and Reina Neufeldt. The Joan B. Kroc Institute for International Peace Studies and Catholic Relief Services, Southeast East Asia Regional Office, 2007. http://www.nd.edu/~krocinst/documents/crs_reflective_final.pdf
- *Theory of Change: A Practical Tool for Action, Results, and Learning.* Organizational Research Services for the Annie E. Casey Foundation, 2004. <http://www.aecf.org/KnowledgeCenter/Publications.aspx?pubguid={33431955-1255-47F4-A60B-0F5F3AABA907}>

measurement of each indicator was tailored to the local context while retaining a breadth that would allow findings to be aggregated across countries and programs.

The researchers encountered several challenges while developing indicators, including lack of consensus in the practitioner community about how broad or context-specific indicators should be, an overwhelming number of potential indicators, and a complex diversity of disciplines (including international development practice, economics, social psychology, and political science) from which the indicators were drawn. Indicator and tool development were ultimately successful due to an iterative process of drafting and revision: as theory and practice became more clear, tool development began to arise as a complementary process of developing the indicators.

5. Data Collection Tools

Challenges of Data Collection in Conflict-Affected Environments

Mercy Corps' ability to evaluate programs implemented in conflict-affected environments has also been undermined by challenges that raise ethical concerns and risk compromising the accuracy and integrity of the data collected. These challenges include:

1. *The sensitivity of the information.* Due to the sensitive nature of the information being collected, participants may be unwilling to speak honestly or openly and government partners may be reluctant to permit data collection.
2. *The complex and dynamic context.* The multiple causes, fluid dynamics, and local specificity that characterize conflict make it difficult for outsiders to rapidly understand the situation, avoid oversimplification, and correctly attribute cause and effect.
3. *The risk of exacerbating conflict and doing harm.* Asking questions may fan emotions, reignite grievances, and spur additional conflict.
4. *Concerns about the safety of participants and staff.* Sharing sensitive information may put participants at risk for retaliation, and high levels of insecurity may pose a threat to staff working in the area.
5. *Logistical constraints.* Poor travel conditions, limited communications, insecurity, and low local capacity may delay or prevent data collection.

Mercy Corps sought to overcome these challenges by developing tools and techniques that aim to collect information sensitively with minimal risk of exacerbating conflict, capture local perceptions and rich contextual detail, and ensure high quality, accurate data collection across varying degrees of capacity in the field.

Overview of Tools

Over the life of the research project, Mercy Corps developed and field-tested three different types of data collection tools, including surveys, monitoring forms, and participatory assessment tools. The process of developing indicators and tools was iterative and complementary: inspiration for new indicators was drawn from thinking systematically about which indicators best measure each theory of change and considering how to tailor the tools to the local context.

Surveys	Uganda/Building Bridges to Peace midterm survey
	Ethiopia/Strengthening Institutions for Peace and Development baseline survey
	Indonesia/ Maluku Economic Recovery Program II midterm survey
Monitoring Forms	Violent Incident Reporting Form
	Dispute Resolution Reporting Form
Participatory Assessment Tools	Scored Community Relationship Mapping
	Internal Actor Mapping
	Conflicts & Resource Mapping
	Disputes & Dispute Resolution Scoring

Surveys

Survey questions focused on several key topics, including:

1. *Security* (e.g., incidence of violence, freedom of movement);
2. *Relationships between communities* (e.g., trust, social and economic interactions, exclusion, cooperative behavior, sources of tension);
3. *Dispute resolution* (e.g., dispute resolution actors and mechanisms, success of dispute resolution); and
4. *Livelihoods* (e.g., economic interactions, access to resources, market behavior, income, agricultural production).

The primary purpose of the surveys was to generate sufficient quantities of data to detect statistically significant patterns. To develop the surveys, the research team reviewed a range of Mercy Corps surveys as well as 18 external surveys drafted by both academics and practitioners in order to learn about the variety of ways to ask conflict-focused and conflict-sensitive questions (see Annexes 8.3, 8.4, and 8.5). The survey was piloted and implemented first in Ethiopia, and then revised and adapted for use in both Uganda and Indonesia. A number of similar questions were asked across all three countries in order to facilitate comparison of results. The survey data provided reliable descriptive information as well as enough data to run statistical analyses.

Participatory Assessment Tools

The research team developed four participatory assessment tools: Scored Community Relationship Mapping, Internal Actor Mapping, Conflicts & Resource Mapping, and Disputes & Dispute Resolution. These tools were intended to triangulate similar data gathered through the survey. In addition, they complemented the survey by capturing rich qualitative and contextual information, emergent phenomena, and beneficiary views. For example, these tools elicited community explanations of the causes of cattle raiding, local definitions of peace, and descriptions of the characteristics of successful dispute resolution actors. In addition to generating data useful for monitoring and evaluation, these tools were particularly useful in collecting information required for program design and planning. While each tool can be used independently, using all four tools together provides a comprehensive overview of conflict in a given location.

Tool	Objective
Scored Community Relationship Mapping	<ul style="list-style-type: none"> • To identify the communities and external actors involved in a given conflict • To describe the relationships between these actors, including social and economic interactions that characterize these interactions
Internal Actor Mapping	<ul style="list-style-type: none"> • To identify the internal actors who both mitigate and aggravate a given conflict • To explore the driving factors behind these actors' actions
Conflict & Resource Mapping	<ul style="list-style-type: none"> • To identify local resources that the community uses or needs/wants to use but can't access • To explore the relationship between local resources and conflict
Disputes & Dispute Resolution Tool	<ul style="list-style-type: none"> • To identify the actors involved in local dispute resolution and evaluate how effective they are • To identify common types of local conflict

The participatory assessment tools draw on techniques common in participatory rural appraisal (PRA) and participatory impact assessment (PIA),³ combining open-ended discussion questions with techniques such as ranking and proportional piling that facilitate quantification and allow for the systematic collection of data. This in turn makes it easier to compare program impacts across time and across sites. In order to develop the tools, the research team reviewed these participatory techniques and incorporated them in the new tools to focus data collection on issues related to conflict. The four tools were first field tested in Ethiopia. With some minor adaptations to the program and local context, three of the tools were subsequently implemented in Uganda and two were implemented in Indonesia.

Participatory Assessment: Strengths and Weaknesses

Strengths

- Tools uncovered new information about the conflict, even for staff who knew the context well.
- Open-ended questions and discussion format allowed unexpected information to surface.
- Discussions served as a program activity as well as an assessment activity, enabling participants to analyze and reflect on the conflict and to discuss solutions to promote peace.
- Tools allowed collection of context-specific information as well as community descriptions of causes and processes.

Weaknesses

- More time consuming to implement than a survey.
- Required intensive training of facilitator and note-taker.
- Challenging to analyze qualitative data systematically and rigorously.
- Data cannot be generalized because the sample size is too small.

³ For more information, see *Participatory Impact Assessment: A Guide for Practitioners*. Andrew Catley, John Burns, Dawit Abebe, and Omeno Suji. Tufts University Feinstein International Center, 2008.

<https://wikis.uit.tufts.edu/confluence/display/FIC/Participatory+Impact+Assessment>

Overcoming the Challenges of Data Collection in Conflict-Affected Environments

Challenge	Solutions
Working with the Host Country Government	
<ul style="list-style-type: none"> • Gaining support for data collection • Minimizing government influence over data collection • Protecting participants from retaliation • Collecting information about government involvement in conflict • Avoiding close identification with government 	<ul style="list-style-type: none"> • Secure permission for data collection activities • Request that only specific types of people (e.g., women or youth) be present during data collection • Hold meetings in locations unlikely to be visited by government officials • Minimize government involvement in recruiting participants for focus group discussions • Use terms like “peace” and “tense relationships” instead of “conflict” • Avoid working with traditional institutions that support harmful traditional practices, oppress certain groups, or are in competition with the government
Protecting the Safety and Security of Participants	
<ul style="list-style-type: none"> • Dealing with reluctance to speak openly due to security concerns • Reducing the risk of retaliation 	<ul style="list-style-type: none"> • Assure participants that data will be kept anonymous • Do not record participant names • Allow participants to refrain from answering questions they are uncomfortable with • Maintain the security of collected data • Minimize involvement of government and security personnel
Complex Conflict Context	
<ul style="list-style-type: none"> • Understanding multiple causes of conflict and varying interpretations of history • Generalizing across programs and locations despite context specificity • Understanding a dynamic situation where information may quickly become obsolete • Understanding stability in a post-conflict environment • Difficulty attributing cause and effect 	<ul style="list-style-type: none"> • Create tools that allow for the collection of unexpected, emergent information • Ask open-ended questions • Triangulate data by collecting it through a variety of sources • Draw on local knowledge • In a post-conflict context, frame questions around how to maintain peace and stability • Root information gathered to a particular time period • Gather detailed qualitative data about specific sites while creating broader quantitative tools that allow for analysis of general patterns • Create a common language among research sites that allows for linkages
Do No Harm	
<ul style="list-style-type: none"> • Understanding unintended consequences • Reducing the risk of exacerbating conflict • Reducing the likelihood of re-traumatizing participants 	<ul style="list-style-type: none"> • Maintain neutrality and impartiality • Frame questions sensitively • Frame questions positively, e.g. in terms of what is needed to maintain peace and stability • Train data collectors in conflict sensitivity and to be responsive to the mood of participants • Employ facilitators and enumerators from the target community • Be willing to halt the assessment if necessary • Adjust data collection tools as necessary to adapt to different communities
Sensitivity of the Topic	
<ul style="list-style-type: none"> • Ensuring accuracy • Encouraging participants to speak openly and honestly • Alleviating government concerns • Minimizing risk to participants 	<ul style="list-style-type: none"> • Create an environment in which people feel comfortable speaking freely • Minimize government involvement in data collection • Maintain anonymity of participants • Train facilitators and enumerators to probe sensitively • Develop context-specific ways to probe when bias or exaggeration is suspected
Measuring Intangible Change	
<ul style="list-style-type: none"> • Quantifying intangible concepts such as trust and relationships • Detecting changes over time 	<ul style="list-style-type: none"> • Collect data on attitudes, beliefs, and behaviors • Create proxy indicators • Seek to corroborate findings about attitudes with findings about behaviors • Use participatory tools to encourage participants to express feelings in a more informal, candid way

Monitoring Forms

The research team developed two monitoring forms: the Violent Incident Reporting Form and the Dispute Resolution Reporting Form (see Annexes 8.12 and 8.13).

1. The *Violent Incident Reporting Form* was designed to achieve two key goals: to gather data on violent incidents as they occurred, and to reinforce community monitoring and response to the conflict. These forms were thus filled out by voluntary, community-based monitors. This data collection strategy posed some challenges, such as incorrectly filled forms and irregular receipt of forms, leading to concerns that this data was less reliable than the survey data. In order to enhance reliability, staff will contact community-based monitors at regular intervals to collect data and verify reported incidents.
2. The *Dispute Resolution Reporting Form* was designed to track the resolution of specific disputes. Because of the data collection challenges with the Violent Incident Reporting Form, this form was filled out by staff members during monthly visits to community-based dispute resolution actors.

Sample Form Questions

Violent Incident Reporting Form

- When did the incident occur?
- What type of incident occurred?
- What were the consequences of the incident?
- Who was involved in the incident?

Dispute Resolution Reporting Form

- Who were the actors involved in resolving the dispute?
- What process did these actors follow to resolve the dispute?
- Was the dispute resolved successfully? Why or why not?
- Provide detailed information on the agreement reached.

Recommendations for Future Tool Development

Challenges with data collection and analysis point toward a number of recommendations for improving data collection tools in the future, including:

- Ask a minimum number of key questions;
- Avoid nuanced questions that generate little additional information;
- Work with the data analyst to design both the tools and the data entry procedures; and
- Field testing new measures should include data entry and analysis.

The key steps in developing tools are:

1. *Determine which theories of change will be tested, articulate the research questions to be answered, and identify the indicators that will be observed through use of the tool.* This information should be captured in a methodology/design document describing the upcoming data collection activity (e.g., baseline or midterm assessment).
2. *Research similar tools to learn about best practices.*
3. *Develop tools.* Create the new tools tailored to program's data needs. Tool should be developed in collaboration with field staff. This increases ownership, ensures the tools are appropriate to the local culture, ensures the tools are relevant for the program, and provides training opportunities.

4. *Field test tools.* This allows the tools to be piloted while training field staff in their use.
5. *Revise and finalize the tool,* capturing observations about the tool's weaknesses and strengths as well as tips for good implementation.

All tools should consist of three documents in order to minimize error and miscommunication:

1. *The tool itself,* e.g., the survey questionnaire, the focus group discussion guide, the participatory assessment guide.
2. A *manual* explaining how the tool is to be used. In the case of a survey, the manual is a separate document that explains what each question means and how the respondent's answer is to be recorded. In the case of a qualitative data collection guide, the "manual" may be integrated into the guide itself. The manual does not obviate the need for hands-on training of the people who will actually collect the data.
3. A *data entry form* (e.g., an Excel spreadsheet for quantitative data, a Word document articulating key questions that should be answered through a focus group discussion). This helps to minimize errors in data entry and ensure that the key questions are addressed.

Tips for Training Staff on Participatory Assessment Techniques

1. **Combine "classroom" learning with practical application.** Review and practice the tool in the office, then practice using the tool in the field with supervision from the trainer.
2. **Train in a small group** of 6-10 facilitators. This allows the trainer to ensure that each trainee understands the tool as well as the local context.
3. **Model good participatory facilitation** by including trainees in every phase. This will reinforce training on participatory techniques.
4. **Be conflict-sensitive during the training itself.** If facilitators come from different conflicting communities, include bridging icebreaker activities and ensure that groups intermix.
5. **Train note-takers** rigorously, ensuring that they understand the objectives of the tool, key research questions, and the correct way to record information.
6. Facilitators should **use the tool in the field at least two times with supervision** before beginning to use the tool independently. Provide feedback on the use of the tool as well as facilitation skills after each supervised field training session.
7. Ask facilitators to **share their knowledge of the culture and geographic area.** Especially in conflict contexts, facilitators must make every effort to respect community values and make a good impression on participants.
8. **Discuss the nature of the conflict.** Engaging facilitators in analysis of the conflict will help them understand the context and promote ownership of the results.
9. **Discuss how to word sensitive questions.** Asking questions skillfully can overcome many worries about broaching delicate topics.
10. Encourage facilitators to **anticipate potential biases.** Practice sensitive probing for when facilitators suspect that participants are not providing complete responses.
11. **Determine common translations for key conflict words.** Having a common language for discussing conflict will increase comparability across focus groups.
12. Drive home that **facilitators should seek to gain consensus** during discussion groups while ensuring that participants feel comfortable voicing opposition. In conflicting communities, no one must leave the discussion feeling marginalized or silenced.
13. Have facilitators **practice the introduction several times.** Introductions that clarify the purpose of the exercise are especially important in a conflict context when communities may be over-researched, skeptical of outsiders, accustomed to handouts, and generally frustrated.

Measuring Violence in Uganda

Measuring the incidence of violence ethically and accurately is notoriously difficult. Community members may be unwilling or unable to share such sensitive information due to security concerns, personal trauma, or lack of knowledge. Government partners may not permit data collection explicitly related to conflict. It can also be difficult to determine the relationship between specific incidents and wider communal conflict.

In order to minimize these challenges, Mercy Corps developed five unique tools to collect different information about violent incidents. These tools focus on observed behaviors while soliciting community perspectives on the causes of conflict. The tools include an individual survey, the Violent Incident Reporting Form, Conflict & Resource Mapping, Disputes & Dispute Resolution, and Internal Actor Mapping.

Preliminary findings from this array of tools include:

- An average of six violent incidents occurred in each community over the previous three months. (*Survey*)
- Cattle raiding is the most common type of violent incident in Karamoja. Other common incidents include killings, household thefts, and land disputes. (*Survey, Violent Incident Reporting Form, Disputes & Dispute Resolution*)
- 33% of violent incidents reported from September 2009 through May 2010 resulted in death, while 25% resulted in material damage, 19% in serious injury, and 10% in minor injury. (*Violent Incident Reporting Form*)
- Cattle raiding has the most negative impact on communities, followed by ambushes, land disputes, fighting domestic violence, petty theft, and gender-based violence. (*Disputes & Dispute Resolution*)
- Eight of nine focus groups cited an inability to access resources, generally farmland or grazing areas, due to insecurity. (*Conflict & Resource Mapping*)
- Insecurity prevented people from going to the market (62%), accessing pasture (53%), going to their fields (46%), or going to work (25%). (*Survey*)

6. Conclusions

Measuring impact

The central goal of the research study was to *develop and test measures and tools that could start to capture relationships between economic variables and stability outcomes*. Preliminary findings show that it is possible to measure shifts in economic and stability indicators and that, in some cases, these factors are correlated. This represents a significant step forward in terms of developing more robust tools for examining the relationship between economic interventions and conflict at the program level. Most exciting, while the research project has ended, Mercy Corps' field teams are continuing to use, refine, and adapt the tools developed through this project and are beginning to show evidence of impact.

Lessons learned about development of indicators and data collection tools over the course of this research project include:

- Focus on a limited number of more precise, less nuanced questions in both survey and focus group data to simplify data analysis and minimize ambiguous results.
- Simplify participatory tools and surveys so that they take less time to administer, more interviews can be conducted, and sample size can increase.
- Favor forced choice questions in the survey instrument.

- While the development of indicators and data collection tools are crucial first steps in impact evaluation, they are not sufficient alone. The ability to measure impact depends on the design of the research methodology and particularly the use of control groups.
- Better tools are needed to assess underlying tensions and risk of future conflict in locations where there is an absence of overt violence.

Economic development for peacebuilding

The preliminary findings from this research project support the idea of using economic development as a tool to build peace: to provide opportunities for positive interaction, to foster interdependence, to create incentives for peaceful coexistence, and to achieve mutually beneficially goals. At the same time, the findings show that all economic development approaches are not equal. Different types of economic activities lead to different outcomes in different contexts. In order to effectively use economic development as a tool to promote peace, implementing agencies need to better understand the variety of peacebuilding outcomes produced by diverse economic interventions. Moreover, a more nuanced approach must be adopted in order to design tailored economic activities designed to target specific drivers of conflict. Further research to explore the impact of different economic development interventions and the conditions under which economic development may promote peace is needed.

The findings of this research project point toward a number of recommendations for developing economic interventions for peacebuilding, including:

- Economic development interventions should be designed to promote mutually beneficial cooperation rather than increasing competition between adversarial groups.
- Economic development interventions designed to promote peace should specifically target the underlying economic causes of conflict (e.g., natural resource competition) rather than aiming to increase general economic interactions between adversarial groups.
- “Deep” economic interactions (such as participation in economic associations or business partnerships) may build stronger relationships between adversarial groups and provide a stronger incentive for peace than “thin” economic interactions (such as trading at a local market).
- Trust-building measures may need to be implemented alongside or prior to economic development interventions in order to develop the relationships necessary for business partnerships and trade.

Global Headquarters

Mercy Corps
45 SW Ankeny Street
Portland, Oregon, 97204
800.292.3355
www.mercycorps.org

Annex 8.1 Peace & Stability Indicator Menu

N°	Indicator	Indicator Definition, Unit of Analysis, and Disaggregates
Peace and Security		
1	% change in perceptions of peace and security	This indicator measures how people rank the area they live in relation to surrounding areas in terms of general levels of peace and security. It also asks whether levels of current peace/stability have changed in the past year to gather information on trend lines. Disaggregate by location.
2	% change in # of respondents who are hopeful about a peaceful future	This indicator measures whether people believe whether it is possible to address causes of instability in their area or whether it is possible to live in peace with a former adversary.
3	% change in reported incidents of violence.	Incidents of violence are site specific and can include raids, burning of houses, killings, thefts, ambushes, or other events defined by the community. Incidents are disaggregated by location, type, frequency, and severity/impact.
4	% change in freedom of movement	% of respondents reporting increased or decreased ability to move freely in order to meet basic needs and pursue livelihoods (access fuel, water, farm, go to school).
5	% change in the size of "no-go" or contested areas	"No go" or contested areas are places that respondents avoid due to insecurity or because local leaders have placed them 'off limits' (generally because they are contested or are meant to serve as a buffer between warring groups). This indicator measures increases or decreases in <i>the size of</i> these areas over the life of the program. If possible, this should be measured in hectares. Disaggregate by location and type of area (e.g. administrative boundary, farmland, forest, grazing area).
6	# of displaced as a % of local population	This indicator is designed to capture the impact of conflict and should supplement the violent incidents indicator. It is important to ask why people have been displaced, since displacement may not necessarily be due to conflict but may have been caused by environmental/other issues such as drought.
Peacebuilding Training, Dispute Resolution, and Negotiated Agreements		
7	# of people trained in peacebuilding/dispute resolution	# of people who participate in (and complete) a peacebuilding training program. Disaggregate by gender, age, region, and profession.
8	% change in participants' knowledge of peacebuilding/dispute resolution approaches	# of participants who participate in peacebuilding training program who report greater knowledge of conflict management skills and approaches by the end of the program. Disaggregate by age, ethnicity, region, profession, and sex
9	% change in participants' confidence in using negotiation/peacebuilding skills	# of participants who participate in peacebuilding training program who report greater confidence in using conflict resolution tools by the end of the program. Disaggregate by gender, age, region, profession, and ethnicity
10	% change in knowledge about local dispute resolution actors/institutions	This indicator measures how much respondents know about local resources for resolving conflict. By asking follow-on questions about the type, frequency, and severity of disputes that each actor/institution can address, it also provides a measure of how effective people believe these institutions are. If actors/institutions are seen as capable of taking on more disputes - or more severe/complex disputes - over time, this can feed into measures of increased confidence in local systems.

11	% change in perceptions of effectiveness of local conflict resolution actors/institutions	This indicator measures changes in levels of satisfaction with local dispute resolution actors and institutions. The precise definition of 'satisfaction' will change according to country context, but generally will include questions about effectiveness, fairness, and legitimacy of decisions taken by these actors. Disaggregate by sex, age, location, occupation, ethnicity
12	% change in # of people who are satisfied with the outcome of agreements	This measures satisfaction with agreements, not the actors who resolve disputes. Satisfaction will be context specific and can incorporate elements of legitimacy, fairness, levels of community support, or adherence to respected norms/traditions.
13	% change in attitudes toward peace and violence	% change in number of program participants who believe that violence is an acceptable/preferred strategy for resolving disputes
14	% change in attitudes about which groups have a meaningful/legitimate role to play in dispute resolution	This indicator measures the inclusiveness of dispute resolution processes. In many countries, dispute resolution is viewed as the preserve of (often male) elders or traditional leaders. This indicator measures whether these leaders begin to recognize the importance of including other voices in dispute resolution. This will often be marginalized groups, but it may also include formal government officials, private sector actors, civil society, or other groups that have not traditionally had a seat at the dispute resolution table
15	# of disputes resolved by program participants using new skills	This indicator measures whether participants are using skills received through Mercy Corps trainings to resolve disputes. This is self-reported on agreement forms and can be seen from the description of the dispute resolution process and dispute resolution tools that are used in negotiations. Disaggregate by location, type of dispute, and negotiator/program participant
16	% change in # of disputes resolved by program participants	% change in the # of disputes resolved by program participants using approaches or methods gained through MC programs. Disaggregate by type of dispute, complexity of dispute, and program participant. (ethnicity, sex, age, region).
17	# of agreements that last at least 6 months	# of agreements that last at least six months, measured from the end date of negotiations, disaggregated by negotiator, type of dispute, and region.
18	# of people who directly and indirectly benefit from an agreement	# of people who benefit directly and indirectly from the resolution of a particular dispute, for example, a land dispute or an economic dispute. Disaggregate by ethnicity (if possible).
Peacebuilding Projects and Initiatives: Levels of Interaction and Attitudes		
20	# of peacebuilding projects implemented	This indicator measures the number of peacebuilding projects implemented. Peacebuilding projects include dialogues, cultural events, community projects, and other activities. Disaggregate by location, project type, and beneficiaries.
21	# of people who directly and indirectly benefit from peacebuilding projects	This indicator measures the number of people who participate in peacebuilding projects. Disaggregate by ethnicity, gender, and age.
22	Level of community/local support for peacebuilding initiatives	This indicator measures the the level of in-kind or cash contributions that local actors (communities, local government actors, local businesses, etc.) make to peace initiatives. Not clear yet that we need to measure this at baseline - right now it is part of the PPIF only.
23	% change in interaction between members of different groups	Interactions include a wide range of social, economic, and political behaviors that bring different groups into regular contact with each other. Disaggregate by type of interaction (social, economic, and political) and frequency.
24	% change in willingness to interact with members of a different group	This measures <i>willingness</i> to interact as opposed to actual interaction.
25	% change in the number of people who can articulate a concrete, tangible benefit from interacting with a different group	This indicator measures whether groups can articulate clearly what they gain from a relationship with another group. The assumption is that if they see a clear gain from interaction, they will feel a loss if the relationship is severed through violence.

26	% change in the quality of relationships between different groups	This indicator measures respondents perceptions of whether they have a good or bad relationship with other (identified) communities. Disaggregate by sex, age, location, occupation, and ethnicity.
27	% change in negative stereotypes about members of different groups	Negative perceptions include negative or derogatory feelings, attitudes, and stereotypes about the other group. These are likely to be very context specific. Disaggregate by age, ethnicity, and sex.
28	% change in levels of trust between members of different groups	This indicator measures whether respondents trust other communities or feel comfortable/uncomfortable with a proposed series of interactions with a different community, such as inter-marriage or employment.
29	% change in perceptions of exclusion by other groups	This indicator measures whether respondents feel that they are excluded from key social, political, and economic activities by other groups. Disaggregate by type of activity.

Annex 8.2 Economics & Conflict Indicator Menu

N°	Performance Indicator	Indicator Definition, Unit of Analysis, and Disaggregates
ECONOMIC INTERACTION		
1	% change in level of economic interaction between members of conflicting communities	<p>Definition: Level of economic interaction: Individuals and groups interacting in the production, distribution and consumption of goods and services</p> <p>Unit of Analysis: A scale of low, medium, high level of economic interaction</p> <p>Disaggregates: Individual, group, formal, informal</p>
2	% change in frequency of economic interaction between members of conflicting communities	<p>Definition: Economic interaction: Individuals and groups cooperating in the production, distribution and/or consumption of goods and services.</p> <p>Unit of analysis: Individuals and groups</p> <p>Disaggregates: By type of economic interaction: production, distribution and/or consumption.</p>
3	% change in type of economic interaction between members of conflicting communities	<p>Definition: Change in # of ways individuals and groups are cooperating in the production, distribution and consumption of goods and services</p> <p>Unit of Analysis: Type of economic interaction</p> <p>Disaggregates: By production, distribution and consumption</p>
4	% change in willingness to economically interact with members of conflicting communities	<p>Definition: The extent to which respondents/beneficiaries are willing to interact economically compared to the beginning of the intervention.</p> <p>Unit of Analysis: # of individual survey respondents indicating a willingness to interact economically in the future with members of conflicting communities</p> <p>Disaggregates: By type of economic interaction (production, distribution, consumption)</p>
5	% change in levels of market-based interaction between members of conflicting communities	<p>Definition: Extent to which members of conflicting communities go interact at their local market</p> <p>Unit of analysis: A scale of low, medium, and high</p> <p>Disaggregates: Market location</p>
6	% change in # of formal economic associations between members of conflicting communities	<p>Definition: Formal economic associations are those that are registered as associations/livelihood groups that exist for the improved economic well being of their members</p> <p>Unit of analysis: Association</p> <p>Disaggregates: Type of association</p>
7	% change in type of formal economic associations between members of conflicting communities	<p>Definition: Type of activity of the economic association (will vary from site to site, could be agriculturally based, such as coco farming or coconut oil production)</p> <p>Unit of Analysis: Economic association</p> <p>Disaggregate: By type of association</p>
8	% change in # of members of divided communities participating in existing livelihoods institutions/associations	<p>Definition: Individuals recognized as active participants in livelihoods associations representing divided communities</p> <p>Unit of analysis: individual members</p> <p>Disaggregates: By community</p>
9	% change in # of joint economic projects supported that bring conflicting communities together	<p>Definition: Change in the number of cooperative initiatives aimed to improve capabilities, assets and activities required for a means of living comprised of communities with a history of tension</p> <p>Unit of analysis: Economic projects rojects</p> <p>Disaggregate: by type of initiative, location of community members</p>

10	% change in trade between members of divided communities.	Definition: % increase of trade volume or value of specific good or service over time . Unit of analysis: Volume or value of specific goods Disaggregates: By type of good traded
11	# of jointly owned businesses including members of divided communities	Definition: Jointly owned businesses are profit-seeking ventures that are under the proprietorship of individuals/groups with a history of tension Unit of analysis: # of businesses Disaggregates: Type of business, by community
12	# of new business contracts between members of divided communities.	Definition: # of agreements to establish or expand a business between members of divided communities Unit of analysis: Business agreements Disaggregates: Types of businesses, location
13	# of joint marketing for products and services between members of divided communities	Definition: Collaboration to expand market base of products developed by beneficiaries of communities with a history of tension Unit of analysis: marketing initiatives Disaggregates: Type of products, communities
14	% change in perceived benefits from economic interaction with members of community X	Definition: Percent change in number of people who can name specific economic benefits (e.g., productive efficiencies) as a result of interactions between groups with a history of tensions Unit of analysis: % change in individuals Disaggregate: Type of economic benefit
15	% change in # of people who perceive tangible, concrete economic benefits from interaction with a former adversary	Definition: # of people who attribute improvement in economic well-being to interaction with a former adversary Unit of analysis: Individuals Disaggregates: Type of benefits
16	% change in # of people who believe that their economic well-being and/or future is dependent on their economic relationship with the other group	Definition: # of people who perceive their access to economic resources, economic security, etc. is dependent upon their economic cooperation with the other group Unit of analysis: Individuals Disaggregates: Gender, location, age group
<i>Access to Resources (due to economic relationships)</i>		
17	% change in # of shared economic resources between members of conflicting communities	Definition: Any resources utilized for economic well-being that is shared by members of conflict communities Unit of analysis: Resource Disaggregates: By type of economic resource
18	% change in type of shared economic resources between members of conflicting communities	Definition: Any resources utilized for economic well-being that is shared by members of conflict communities Unit of analysis: Resource type Disaggregates: By type of economic resource
19	% change in number of shared economic resources that reflect terms of a negotiated agreement.	Definition: Any resources utilized for economic well-being that is shared by members of conflict communities and where the terms for managing the resource were agreed upon through a negotiated process Unit of analysis: Negotiated agreements Disaggregates: Type of resource
ECONOMIC DEVELOPMENT		
20	% change in # of livelihood opportunities	Definition: # of possible ways for individuals to make a productive living attributable to project interventions Unit of analysis: Livelihood means Disaggregates: Type of opportunity

21	% change in type of livelihood opportunities	Definition: Change in the number of primary livelihood sources (e.g., cash crops, small business, etc.) that individuals use attributable to project interventions Unit of analysis: Type of livelihood Disaggregates: By type
22	# of jobs created	Definition: # of jobs and employment opportunities created for participants directly involved in project interventions (e.g., market vendors who are able to set up shop in markets built through joint livelihoods projects) Unit of analysis: # of jobs created over a specified period of time Disaggregate: By type, by location
23	% change in beneficiary income	Definition: % of survey respondents reporting change in income (increase or decrease) over the life of the project. Unit of analysis: self-reported perceived change in income (increase, decrease, no change) Disaggregates: By location, gender
24	% change in beneficiary assets	Definition: % increase or decrease of anything tangible or intangible that is capable of being owned or controlled to produce value and that is held to have positive economic value Unit of analysis: Self reported perceived change in assets Disaggregate: By location, type of assets
25	% change in # of people in target communities who express greater hope in their economic future	Definition: Percent change in the number of people in believe there are currently livelihood options for them or there will be in the future.
26	% change in # of people worried about being able to find a livelihood	Definition: # of respondents expressing concern about their ability to meet their basic needs, the needs of their family Unit of analysis: Individual survey respondents Disaggregates: By location, gender, age group
27	# of new economic resources created	Definition: # of new sources/inputs for economic/livelihood improvements (eg new water points, new trees) Unit of analysis: resource Disaggregate: By type of resource
ECONOMIC INCLUSION		
28	% change in feelings of economic exclusion between members of conflicting communities	Definition: Perceptions of exclusion from access to markets, economic resources for economic well-being Unit of analysis: Individuals Disaggregate: Location, gender
29	% change in # of marginalized people who attend community meetings about local economic development activities	Definition: Participation in economic development activities by groups historically left out of such processes/groups who view themselves as economically or politically disenfranchised), or those who are especially vulnerable to the impact of violent conflict (e.g., women, young children, ethnic or religious minorities). Unit of analysis: Individuals belonging to marginalized groups Disaggregate: by marginalized group
30	% change in # of marginalized people who participate in local economic development activities	Definition: Number of people from marginalized or 'at-risk' groups who have participated in civic and/or economic development activities specifically conducted to benefit members of such groups. Unit of analysis: Individuals belonging to marginalized groups Disaggregates: By marginalized group
31	% change in % of community action group members who are from marginalized communities	Definition: # of marginalized individuals participating community based development group Unit of analysis: Community action group members Disaggregation: By location, type of marginalized group

32	% change in belief among marginalized group members that they have the same economic opportunities as other groups	Definition: Change in perceptions of equitable access to economic opportunities by marginalized groups Unit of analysis: Individual members of marginalized groups Disaggregation: By location, type of marginalized group
33	% change in # of marginalized people who feel included in local decision making processes about economic development	Definition: Perception of inclusion in decision making about economic development by members of marginalized groups Unit of analysis: Individual members of marginalized groups Disaggregation: By type of marginalized group, by location
34	% change in economic behaviors by marginalized groups that signal status in their context	Definition: Economic behavior that signals status Unit of analysis: Individual members of marginalized groups Disaggregation: By type of economic behavior, location, by type of marginalized group
35	% change in # of marginalized people who feel they will benefit from local economic development initiatives	Definition: Perception that the locally initiated economic development activities include them (members of marginalized groups) Unit of analysis: Individual member of marginalized group Disaggregate: Type of marginalized group, location
36	% change in # of people from marginalized group who express greater satisfaction with their economic position	Definition: Individuals who positively assess their economic position in the community Unit of analysis: Individuals from marginalized groups Disaggregates: Location, type of marginalized group
37	% change in # of people from marginalized groups who feel their economic position relative to the dominant economic group has improved	Definition: Perception of relative upward economic mobility of marginalized groups Unit of analysis: Individuals from marginalized groups Disaggregates: By location, type of marginalized group
38	% change in # of marginalized people who are actively planning for their economic future	Definition: Individuals who self-report actively planning for economic future Unit of analysis: Individual members of marginalized groups Disaggregates: Location, type of marginalized group
39	% change in # of marginalized people pursuing activities that will enhance their economic future	Definition: Activities that enhance economic future: training, education Unit of analysis: Individual members of marginalized groups Disaggregates: Location, type of marginalized group
40	% change in # of marginalized group members who express greater hope in economic future	Definition: Change in perception of optimism for future economic well being Unit of analysis: Individual members of marginalized groups Disaggregates: By type of marginalized group, location
ECONOMICS & SECURITY		
<i>Economic Costs & Benefits of Conflict</i>		
41	% change in perceived cost from conflict with members of community X	Definition: Perception of economic costs of conflict with other community Unit of analysis: Individuals Disaggregates: By location, gender, age group
42	% change in # of people who cite economic reasons for not supporting violence	Definition: Individuals who affirm/identify the impacts/costs of conflict on livelihoods as a reason for not supporting violence Unit of analysis: Individuals Disaggregates: By location, gender, age group

43	% change in # of people who see violence as a way to earn money	Definition: Individuals who cite acts of aggression against other individuals, groups as a way to earn money/improve their livelihoods Unit of analysis: Individuals Disaggregates: By location, gender, age group
44	% change in # of people who believe that they will incur economic losses if violence breaks out	Definition: Individuals who indicate that violence will negatively impact their economic well being Unit of analysis: Individuals Disaggregates: Location, gender, age group
45	% change in # of people who say they have something to lose if violence breaks out	Definition: Individuals who cite the potential negative impacts of violence on their well-being either socially, economically or psychologically Unit of analysis: Individuals Disaggregates: Location, age group, gender
<i>Economic Dispute Resolution</i>		
46	% change in knowledge of dispute resolution mechanisms among economic actors	Definition: Individuals who indicate knowledge of services available to peacefully resolve economic disputes Unit of analysis: Individuals Disaggregates: Type of dispute resolution services, location, gender, age group
47	# of economic actors trained in communications, negotiations, and/or conflict management skills	Definition: Total # of people trained on conflict mitigation resolution skills with USG assistance Unit of analysis: Individuals Disaggregates: By gender, age group, location
<i>Access to Resources (due to security)</i>		
48	% change in access to economic inputs and resources	Definition: Increased access to economic inputs necessary for farming and pastoralism, including water, pasture, and fertile farmland Unit of analysis: Individuals Disaggregates: By type of economic input/resource
49	% change in # of economic resources considered off-limits due to insecurity/conflict	Definition: Economic resources avoided due to threats of insecurity Unit of analysis: Economic resources Disaggregates: Type of economic resources

Annex 8.3 Ethiopia Survey

Strengthening Institutions for Peace and Development Baseline Survey

Part 1: Pre-interview data

The interviewer should fill this out before the interview begins.

Part 2: Informed consent

The interview should read this aloud.

#	Category	Answers (and Coding)	Instructions
1.1	Interviewer Name		
1.2	Date	_____/_____/_____	
1.3	Location: Region		
1.4	Zone		
1.5	Woreda		
1.6	Kebele		
1.7	Village		

Hello. My name is _____ and I work with Mercy Corps. Mercy Corps is an international nongovernmental organization that works for peacebuilding and economic development in this region. We are conducting a survey of households and have randomly selected yours. Participation in the survey is voluntary and you are free to decline to answer any or all questions. The results will be kept confidential and will only be used to help Mercy Corps design better programs in this region. This survey usually takes _____ minutes to complete.

Will you participate in this survey?Yes
No

Signature of interviewer	
--------------------------	--

Part 3: Demographic information

I'd like to start by learning a little bit about you. Please remember that your responses will be kept confidential.

#	Category	Answers (and Coding)	Instructions
3.1	Sex	Male.....1 Female.....2	
3.2	Age		

3.3	Religion	Orthodox.....1	
		Muslim.....2	
		Protestant.....3	
		Waqa feta (traditional belief).....4	
		Other (specify).....5	
3.4	Ethnic Group	Somali.....1	
		Oromo.....2	
		Bench.....3	
		Maji.....4	
		Konso.....5	
		Derashe.....6	
		Surma.....7	
		Bero.....8	
		Other (Specify).....9	
3.5	Occupation	Farmer.....1	
		Pastoralist.....2	
		Trader.....3	
		Other (Specify).....4	

Part 4: Security

Now I'd like to ask you some questions about peace and security in your village.

#	Questions	Answers (and Coding)	Instructions
4.1	In relation to levels of violence, where does your village (kebele) belong?	Very peaceful.....1 Somewhat peaceful.....2 Neither peaceful or violent.....3 Somewhat violent.....4 Very violent.....5 Don't know.....6	
4.2a	To your knowledge, have there been any incidents of violence in your village in the last 12 months?	Yes.....1 No.....2	If "No," skip to Q4.3

4.2b	If yes, about how many incidents occurred?	<hr/> <i>(write the number of incidents that occurred)</i>	
4.2c	If yes, what happened? <i>(circle all that apply)</i>	Beating.....1 Killing.....2 Cattle raid.....3 Ambush.....4 Abduction.....5 Household theft.....6 Rape.....7 Other (specify).....8	
4.2d	If yes, were youth involved in perpetrating this incident?	Yes, definitely.....1 Probably so.....2 Probably not.....3 No, definitely not.....4 Don't know.....5	
4.2e	If yes, were women involved in perpetrating this incident?	Yes, definitely.....1 Probably so.....2 Probably not.....3 No, definitely not.....4 Don't know.....5	
4.3	In the last 3 months, were there any areas that you avoided going to or through because of insecurity?	Yes.....1 No.....2	
4.4a	In the last 3 months, did insecurity ever prevent you or a member of your household from....		
4.4bgoing to the market?	Yes.....1 No.....2	
4.4cgetting water for household use?	Yes.....1 No.....2	
4.4dgoing to your field?	Yes.....1 No.....2	
4.4emoving your animals to new pasture?	Yes.....1 No.....2	
4.4fmoving your animals to water?	Yes.....1 No.....2	

4.4gearning money or going to work?	Yes.....1 No.....2	
4.4hgoing to school?	Yes.....1 No.....2	
4.4igetting medical care?	Yes.....1 No.....2	
4.5	Did insecurity prevent you from investing in your livelihood?	Yes.....1 No.....2	

Part 5: Relationships between divided communities

I understand that your community has tense relationships with some other ethnic groups/communities. I'd like to ask you some questions about the relationship between your community and the ones with which you have tense relationships.

#	Questions	Answers (and Coding)			Instructions
5.1	With which ethnic group (community) do you have best relationships? <i>(list up to three other ethnic groups)</i>	1. 2. 3.			
5.2	With which ethnic group (community) do you have the most tense relationships? <i>(list up to three other ethnic groups)</i>	1. 2. 3.			
	The following questions will focus on these tense relationships.	Ethnic Group:	Ethnic Group:	Ethnic Group:	
5.3a	In the last three months, did you interact with people from Xcommunity? <i>(replace X with the name of the community with which the person has a tense relationship)</i>	Yes.....1 No.....2	Yes.....1 No.....2	Yes.....1 No.....2	If no, skip to Q5.4

5.3b	If yes, how did you interact? <i>(Do not read the list. Let the respondent speak. Circle the first three interactions the respondent mentions.)</i>	Trade or at Market.....1 Socially.....2 Farming.....3 Borrowed or lent money.....4 Employment.....5 Conflict.....6 At a wedding.....7 At a funeral.....8 At church or mosque.....9 Other (specify).....10	Trade or at Market.....1 Socially.....2 Farming.....3 Borrowed or lent money.....4 Employment.....5 Conflict.....6 At a wedding.....7 At a funeral.....8 At church or mosque.....9 Other (specify).....10	Trade or at Market.....1 Socially.....2 Farming.....3 Borrowed or lent money.....4 Employment.....5 Conflict.....6 At a wedding.....7 At a funeral.....8 At church or mosque.....9 Other (specify).....10	
5.4a	Think of the market that you go to most frequently. During the past three months, have members of X community gone to that market, too? <i>(replace X with the name of the community with which the person has a tense relationship)</i>	Yes.....1 No.....2 Don't know.....3	Yes.....1 No.....2 Don't know.....3	Yes.....1 No.....2 Don't know.....3	If no, skip to Q 5.5
5.4b	If yes, do they go there at the same time that you do?	Yes.....1 No.....2	Yes.....1 No.....2	Yes.....1 No.....2	
5.4c	If yes, do you ever buy from them?	Yes.....1 No.....2	Yes.....1 No.....2	Yes.....1 No.....2	
	Do you feel that members of X community exclude you from participation in..... <i>(replace X with the name of the community with which the person has a tense relationship)</i>				

5.5a	...education/schools?	Yes.....1 No.....2	Yes.....1 No.....2	Yes.....1 No.....2	
5.5b	...health services?	Yes.....1 No.....2	Yes.....1 No.....2	Yes.....1 No.....2	
5.5c	...transportation?	Yes.....1 No.....2	Yes.....1 No.....2	Yes.....1 No.....2	
5.5d	...community celebrations?	Yes.....1 No.....2	Yes.....1 No.....2	Yes.....1 No.....2	
5.5e	...groupings to obtain a loan?	Yes.....1 No.....2	Yes.....1 No.....2	Yes.....1 No.....2	
5.5f	...community organizations?	Yes.....1 No.....2	Yes.....1 No.....2	Yes.....1 No.....2	
5.6	How much do you trust people from X community? <i>(replace X with the name of the community with which the person has a tense relationship)</i>	To a very small extent.....1 To a small extent.....2 Neither small nor great extent...3 To a great extent.....4 To a very great extent.....5	To a very small extent.....1 To a small extent.....2 Neither small nor great extent...3 To a great extent.....4 To a very great extent.....5	To a very small extent.....1 To a small extent.....2 Neither small nor great extent...3 To a great extent.....4 To a very great extent.....5	
	In regards to someone from X community, would you feel comfortable.... <i>(replace X with the name of the community with which the person has a tense relationship)</i>				

5.7a	...if your brother or sister married them?	To a very small extent.....1 To a small extent.....2 Neither small nor great extent...3 To a great extent.....4 To a very great extent.....5	To a very small extent.....1 To a small extent.....2 Neither small nor great extent...3 To a great extent.....4 To a very great extent.....5	To a very small extent.....1 To a small extent.....2 Neither small nor great extent...3 To a great extent.....4 To a very great extent.....5	
5.7b	...working for them?	To a very small extent.....1 To a small extent.....2 Neither small nor great extent...3 To a great extent.....4 To a very great extent.....5	To a very small extent.....1 To a small extent.....2 Neither small nor great extent...3 To a great extent.....4 To a very great extent.....5	To a very small extent.....1 To a small extent.....2 Neither small nor great extent...3 To a great extent.....4 To a very great extent.....5	
5.7c	...paying them to work in your field?	To a very small extent.....1 To a small extent.....2 Neither small nor great extent...3 To a great extent.....4 To a very great extent.....5	To a very small extent.....1 To a small extent.....2 Neither small nor great extent...3 To a great extent.....4 To a very great extent.....5	To a very small extent.....1 To a small extent.....2 Neither small nor great extent...3 To a great extent.....4 To a very great extent.....5	
5.7d	...paying them to watch your animals?	To a very small extent.....1 To a small extent.....2 Neither small nor great extent...3 To a great extent.....4 To a very great extent.....5	To a very small extent.....1 To a small extent.....2 Neither small nor great extent...3 To a great extent.....4 To a very great extent.....5	To a very small extent.....1 To a small extent.....2 Neither small nor great extent...3 To a great extent.....4 To a very great extent.....5	

Part 6: Dispute resolution: mechanisms and capacity

Now I'd like to ask you some questions about how disputes are resolved in your community.

#	Questions	Answers (and Coding)	Instructions
6.1	Are disputes in this area (including conflicts between communities/ethnic groups) normally resolved satisfactorily so that all sides are satisfied and don't complain in the end or do they continue long into the future?	Tend to endure.....1 Resolved satisfactorily.....2 Don't know.....3	
6.2	During the past year, how often were disputes resolved peacefully in your community?	Never.....1 Rarely.....2 Sometimes.....3 Most of the time.....4 Always.....5 Don't know.....6	
6.3	During the past year, who usually resolved disputes in your community? <i>(Do not read the list. Let the respondent speak. Circle the first three people/institutions the respondent mentions.)</i>	Nobody.....1 Friends or family members.....2 Elders.....3 Local peace building institutions.....4 Religious leaders.....5 Peace committee members.....6 Local government officials.....7 Women.....8 Don't know.....9	
6.4a	Are government officials involved in mediating conflict in your community?	Never.....1 Rarely.....2 Sometimes.....3 Most of the time.....4 Always.....5 Don't know.....6	If "Never" or "Don't know," skip to Q6.5

6.4b	If yes, what kind conflicts they are mediating?	Beating.....1 Killing.....2 Cattle raid.....3 Ambush.....4 Abduction.....5 Household theft.....6 Rape.....7 Other (specify).....8	
6.4c	How often are they successful in resolving conflict?	Never.....1 Rarely.....2 Sometimes.....3 Most of the time.....4 Always.....5 Don't know.....6	
6.4d	If not successful in resolving conflict, what are the reasons behind?	Lack of community acceptance.....1 Lack of government capacity to implement all conflict resolution processes.....2 Others (please specify).....3 I do not know.....4	
6.5a	In the last three months has your household been involved in any disputes with persons from outside the household?	Yes.....1 No.....2	If "No," skip to Q7.1
6.5b	If yes, who was the dispute with? <i>(if involved in more than one dispute, have the respondent think of the most significant dispute)</i>	Family.....1 Friend/Neighbor.....2 Stranger of the same ethnic group.....3 Stranger of a different ethnic group.....4	
6.5c	If yes, what was the nature of the dispute? <i>(circle all that apply)</i>	Land/property rights.....1 Water rights.....2 Issues regarding women/girls.....3 Harm to property/theft/robbery.....4 Other (specify).....5	

6.5d	How was this dispute resolved?	Dispute not resolved.....1 Directly discussed with those involved (without an intermediary).....2 Friends or family members.....3 Elders.....4 Religious leaders.....5 Peace committee members.....6 Local government officials.....7	If “Dispute not resolved,” skip to Q7.1
6.5e	Were you satisfied with the resolution of this dispute?	To a very small extent.....1 To a small extent.....2 Neither small nor great extent.....3 To a great extent.....4 To a very great extent.....5	

Part 7: Conflict sensitivity

I presume that there are a number of development projects implemented in your area either by government or NGOs. Thus, I would like to ask about your participation in the planning and implementing process of these projects. In addition, I would also like to ask you whether these projects aggravate or improve conflicts.

#	Questions	Answers (and Coding)	Instructions
7.1	Do government officials or NGOs consult community members while implementing development projects?	Yes.....1 No.....2 I do not know.....3	
7.2	Do community members participate while government officials and NGOs implement development projects (like water resource construction, rangeland development, health, etc)?	Yes.....1 No.....2 I do not know.....3	
7.3a	Did development projects in the past five years cause conflict between the community members and/or with other ethnic groups?	Yes.....1 No.....2 I do not know.....3	If “No” or “Don’t know,” skip to Q8.1
7.3b	If yes, how did they aggravate conflict?	Increasing competition.....1 Exclusion of some groups in the community2 Disrupted normal resource use pattern.....3 Attract resource users from other areas.....4 Other (specific).....5	

Part 8: Perceptions of youth

I'd like to ask you some questions about youth in your community (their livelihood and behaviors) as there are a lot of youth in your community. Youth are people between the ages of 15 to 24.

#	Questions	Answers (and Coding)	Instructions
8.1	How do the majority of youth earn a living/earn money in your community? <i>(circle the first two things the respondent mentions)</i>	Farming.....1 Livestock keeping.....2 Small businesses/Trading.....3 Daily laboring.....4 Others (specify).....5	
8.2	Do these activities enable youth to meet their basic needs?	To a very small extent.....1 To a small extent.....2 Neither small nor great extent.....3 To a great extent.....4 To a very great extent.....5 Don't know.....6	
8.3a	Do youth in your community ever participate in crime or violence?	Never.....1 Rarely.....2 Sometimes.....3 Most of the time.....4 Always.....5 Don't know.....6	If "Never" or "Don't know," skip to Q8.4
8.3b	If yes, why? <i>(Circle all that apply.)</i>	Lack of means of livelihood (job).....1 Follow traditions of conflict with other groups.....2 Developing of bad behaviors.....3 Other (specify).....4	
8.4a	Is there any institutions, governmental or non-governmental, which support youth in your area?	Yes.....1 No.....2 Don't know.....3	
8.4b	If yes, what kind of support does it provide for the youth?	Credit service for business.....1 Development of recreational centers.....2 Creating employment opportunities.....3 Other (please specify).....4	
	I'm going to read several statements, and I'd like you to tell me how much you agree or disagree with each statement.		

8.5	Youth are responsible members of my community. (They care for the safety of themselves, their families, and the community.)	Strongly disagree.....1 Disagree.....2 Neither agree nor disagree/Don't know.....3 Agree.....4 Strongly agree.....5	
8.6	Youth are productive members of my community (They are engaging in economic activities and wealth creation that benefit themselves, their families, and the community.)	Strongly disagree.....1 Disagree.....2 Neither agree nor disagree.....3 Agree.....4 Strongly agree.....5	
8.7	Youth steal from other people in my community.	Strongly disagree.....1 Disagree.....2 Neither agree nor disagree.....3 Agree.....4 Strongly agree.....5	
8.8	The actions of youth increase conflict with other communities.	Strongly disagree.....1 Disagree.....2 Neither agree nor disagree.....3 Agree.....4 Strongly agree.....5	

Part 9: Perceptions of women

I'd like to ask you some questions about women in your community (their livelihood and behaviors).

#	Questions	Answers (and Coding)	Instructions
9.1	How do women earn a living/earn money in your community? <i>(circle the first two things the respondent mentions)</i>	Farming.....1 Livestock keeping.....2 Small businesses/Trading.....3 Daily laboring.....4 Other (specify).....5	
9.2	When conflict breaks out in your community, what are the roles of women? <i>(Do not read the list. Let the respondent speak. Circle the first two things the respondent mentions)</i>	Preparing food for the fighters.....1 Encouraging fighters with songs.....2 Tending/share raided cattle.....3 Take children and important properties away.....4 Try to mediate contending parties.....5 Other (specify).....6	
9.3	When conflict breaks out in your community, what are the roles of men? <i>(Do not read the list. Let the respondent speak. Circle the first two things the respondent mentions)</i>	Engaging with the fight1 Tending raided cattle.....2 Migrating to other areas.....3 Try to mediate contending parties.....4 Other (specify).....5	
9.4a	Are women affected by conflict differently than men?	Yes.....1 No.....2 Don't know.....3	If "No" or "Don't know," skip to Q9.5
9.4b	If yes, how? <i>(Circle all that apply.)</i>	They are subjected to violence like rape.....1 They will lose small ruminants.....2 Other (specify).....3	
9.4c	If yes, why? <i>(Circle all that apply.)</i>	They do not have weapons to protect themselves....1 They can't run away to remote areas.....2 Other (specify).....3	

9.5	In your community, are women given as wives as part of conflict resolutions practices?	Yes.....1 No.....2 Don't know.....3	
9.6a	In your community, are women involved in traditional conflict resolution?	To a very small extent.....1 To a small extent.....2 Neither small nor great extent.....3 To a great extent.....4 To a very great extent.....5 Don't know.....6	If "No," skip to Q9.7
9.6b	If yes, how are women in your community involved in conflict resolution activities?	Be part of the conflict resolution committee.....1 Advising/counseling their husbands.....2 Curses/withholding blessings before fighting3 Other (specify).....4	
	I'm going to read several statements, and I'd like you to tell me how much you agree or disagree with each statement.		
9.7	Women should be represented in peace committees or in other traditional conflict resolution groups.	Strongly disagree.....1 Disagree.....2 Neither agree nor disagree/don't know.....3 Agree.....4 Strongly agree.....5	
9.8	The actions of women increase conflict with other communities.	Strongly disagree.....1 Disagree.....2 Neither agree nor disagree/don't know.....3 Agree.....4 Strongly agree.....5	

Part 10: Conclusion

Thank you very much for your time. Do you have any questions for me?

Annex 8.4 Uganda Survey

Building Bridges for Peace Midterm Survey

Part 1: Pre-interview data

The interviewer should fill this out before the interview begins.

#	Category	Answers (and Coding)	Instructions
1.1	Interviewer Name		
1.2	Date	____/____/____	
1.3	Location: District		
1.4	Sub-county		
1.5	Parish		
1.6	Village		
1.7	Name of conflicting community across the district border. <i>The name of this community should be inserted in all site-specific questions.</i>	Pader.....1 Kacheri, Kotido.....2 Rengen, Kotido.....3 Nakapelimoru, Kotido.....4 Lolelia, Kaabong.....5 Sidok, Kaabong.....6 Loyoro, Kaabong.....7	

Part 2: Informed consent

The interviewer should read this aloud.

Hello. My name is _____ and I work with Mercy Corps. Mercy Corps is an international nongovernmental organization that works for peacebuilding and economic development in this region. We are conducting a survey of households and have randomly selected yours. Participation in the survey is voluntary and you are free to decline to answer any or all questions. The results will be kept confidential and will only be used to help Mercy Corps design better programs in this region. This survey usually takes _____ minutes to complete.	
Will you participate in this survey?YesNo
Signature of interviewer	

Part 3: Demographic information

I'd like to start by learning a little bit about you. Please remember that your responses will be kept confidential.

#	Category	Answers (and Coding)	Instructions
3.1	Sex	Male.....1 Female.....2	
3.2	Age		
3.3	Ethnic group (circle one)	Acholi.....1 Dodoth.....2 Jie.....3 Other (specify).....4	
3.4	Occupation (circle one)	Farmer.....1 Pastoralist.....2 Agropastoralist.....3 Trader.....4 Other (specify).....5	

Part 4: Livelihoods

Now I'd like to ask you some questions about livelihoods in your community.

#	Questions	Answers (and Coding)	Instructions
4.1	What issues are most important to you? (write response)	_____ _____	
4.2	What kind of economic activities are you involved in at the moment? (multiple – circle all that apply)	Farming.....1 Cattle keeping.....2 Trade.....3 Other (specify).....4	
4.3a	Are there resources that people in your community want or need to use but are unable to access?	Yes.....1 No.....2	If No, skip to Q4.4a
4.3b	If yes, what type of resource? (circle one)	Water.....1 Grazing land.....2 Farmland.....3 Market.....4 Other (specify).....5	
4.3c	Where is that resource located? (circle one)	In my sub-county.....1 In conflicting community named in Q1.7.....2	

		Other (specify).....3	
4.3d	Why can't you access the resource? <i>(circle one)</i>	Insecurity.....1L lack of ownership.....2 No road.....3 Leaders have agreed no one will go there.....4 Other (specify).....5	
4.3e	If yes, what other type of resource? <i>(circle one)</i>	Water.....1 Grazing land.....2 Farmland.....3 Market.....4 Other (specify).....5	If the respondent has finished naming resources, skip to Q4.4a
4.3f	Where is that resource located? <i>(circle one)</i>	In my sub-county.....1 In conflicting community named in Q1.7.....2 Other (specify).....3	
4.3g	Why can't you access the resource? <i>(circle one)</i>	Insecurity.....1L lack of ownership.....2 No road.....3 Leaders have agreed no one will go there.....4 Other (specify).....5	
4.3h	If yes, what other type of resource? <i>(circle one)</i>	Water.....1 Grazing land.....2 Farmland.....3 Market.....4 Other (please specify).....5	If the respondent has finished naming resources, skip to Q4.4a
4.3i	Where is that resource located? <i>(circle one)</i>	In my sub-county.....1 In conflicting community named in Q1.7.....2 Other (specify).....3	
4.3j	Why can't you access the resource? <i>(circle one)</i>	Insecurity.....1L lack of ownership.....2 No road.....3 Leaders have agreed no one will go there.....4 Other (specify).....5	
4.4a	Do people in your community share resources with people from ___? <i>(Site specific: insert name of conflicting</i>	Yes.....1 No.....2	If No, skip to Q4.5a

	<i>community in bordering sub-county as specified in Q1.7)</i>		
4.4b	If yes, what kind of resources do the two communities share? <i>(multiple – circle all that apply)</i>	Water.....1 Grazing land.....2 Farmland.....3 Market.....4 Other (specify).....5	
4.5a	Think of the market that you go to most frequently. During the past three months, have people from gone to that market, too? <i>(Site specific: insert name of conflicting community in bordering sub-county as specified in Q1.7)</i>	Yes.....1 No.....2	If No, skip to Q5.1
4.5b	If yes, do they go there at the same time that you do?	Yes.....1 No.....2	
4.5c	If yes, do you ever buy from them?	Yes.....1 No.....2	
4.5d	If yes, do you ever sell to them?	Yes.....1 No.....2	

Part 5: Security and Stability

Now I'd like to ask you some questions about peace and security in your village.

#	Questions	Answers (and Coding)	Instructions
5.1	In relation to levels of violence, where does your village belong? <i>(circle one)</i>	Very peaceful.....1 Somewhat peaceful.....2 Neither peaceful or violent.....3 Somewhat violent.....4 Very violent.....5	
5.2a	To your knowledge, have there been any incidents of violence in your village in the last 3 months?	Yes.....1 No.....2	If No, skip to Q5.3a
5.2b	If yes, about how many incidents occurred? <i>(write the number of incidents that occurred)</i>	_____	
5.2c	If yes, what happened? <i>(multiple – circle all that apply)</i>	Beating.....1 Killing.....2 Cattle raid.....3 Ambush.....4	

		Abduction.....5 Household theft.....6 Rape/defilement.....7 Other (specify).....8	
5.2d	If yes, how did you hear about these incidents? (<i>multiple – circle all that apply</i>)	Elders.....1 Kraal leaders.....2 Peace committees/Joint Monitoring Teams.....3 Radio.....4 Youth.....5 Local leaders.....6 Nobody.....7 Other (specify).....8	
5.3a	In the last 3 months, were there any areas that you avoided going to or through because of insecurity during the day?	Yes.....1 No.....2	If No, skip to Q5.4a
5.3b	If yes, how often have you gone to those areas in the last 3 months?	Never.....1 Rarely.....2 Sometimes.....3 Frequently.....4	
5.4a	In the last 3 months, were there any areas that you avoided going to or through because of insecurity during the night?	Yes.....1 No.....2	If No, skip to Q5.5a
5.4b	If yes, how often have you gone to those areas in the last 3 months?	Never.....1 Rarely.....2 Sometimes.....3 Frequently.....4	
5.5	In the last 3 months, did insecurity ever prevent you or a member of your household from....		
5.5agoing to the market?	Yes.....1 No.....2	
5.5bgetting water for household use?	Yes.....1 No.....2	
5.5cgoing to your field?	Yes.....1 No.....2	

5.5dmoving your animals to new pasture?	Yes.....1 No.....2	
5.5emoving your animals to water?	Yes.....1 No.....2	
5.5fearning money or going to work?	Yes.....1 No.....2	
5.5ggoing to school?	Yes.....1 No.....2	
5.5hgetting medical care?	Yes.....1 No.....2	

Part 6: Relationships between divided communities

I understand that there some misunderstanding between your community and community (*insert name of sub-county and district from Q1.7*). I would like to ask you some questions about the relationship between your community and this community.

#	Questions	Answers (and Coding)	Instructions
6.1a	In the last 3 months, did you personally interact socially with people from ____? (<i>Site specific: insert name of conflicting community in bordering sub-county as specified in Q1.7</i>)	Yes.....1 No.....2	If No, go to Q6.2a
6.1b	If yes, how did you interact? (<i>Do not read the list. Let the respondent speak. Circle the first three interactions the respondent mentions.</i>)	Social event.....1 Intermarriage/at a wedding.....2 At a funeral.....3 At church or mosque.....4 Other (specify).....5	
6.2a	In the last 3 months, did you personally interact economically with people from ____? (<i>Site specific: insert name of conflicting community in bordering sub-county as specified in Q1.7</i>)	Yes.....1 No.....2	If No, go to Q6.3a
6.2b	If yes, how did you interact? (<i>Do not read the list. Let the respondent speak. Circle the first three interactions the respondent mentions.</i>)	Trade/at the market.....1 Cattle keeping.....2 Farming.....3 Borrowing or lending money.....4 Employment.....5 Other (specify).....6	

6.3a	Would you be willing to interact with people from _____ in the future? <i>(Site specific: insert name of conflicting community in bordering sub-county as specified in Q1.7)</i>	Yes.....1 No.....2	If No, go to Q6.4
6.3b	If yes, how? <i>(Do not read the list. Let the respondent speak. Circle the first three interactions the respondent mentions.)</i>	Social event.....1 Inter-marriage/at a wedding.....2 At a funeral.....3 At church or mosque.....4 Trade/at the market.....5 Cattle keeping.....6 Farming.....7 Borrowing or lending money.....8 Employment.....9 Other (specify).....10	
6.4	Do you trust people from _____? <i>(Site specific: insert name of conflicting community in bordering sub-county as specified in Q1.7)</i>	Never.....1 Rarely.....2 Sometimes.....3 Most of the time.....4 Always.....5	
	In regards to someone from _____, how comfortable would you feel.... <i>(Site specific: insert name of conflicting community in bordering sub-county as specified on Q1.7)</i>		
6.5a	...if your brother or sister married them?	I am very comfortable with this.....1 I am a little comfortable with this.....2 I am neither comfortable nor uncomfortable.....3 I am a little uncomfortable with this.....4 I am very uncomfortable with this.....5	
6.5b	...starting a business with them?	I am very comfortable with this.....1 I am a little comfortable with this.....2 I am neither comfortable nor uncomfortable.....3 I am a little uncomfortable with this.....4 I am very uncomfortable with this.....5	
6.5c	...if someone from that community was your leader?	I am very comfortable with this.....1 I am a little comfortable with this.....2	

		I am neither comfortable nor uncomfortable.....3 I am a little uncomfortable with this.....4 I am very uncomfortable with this.....5	
6.5d	...paying them to watch your animals?	I am very comfortable with this.....1 I am a little comfortable with this.....2 I am neither comfortable nor uncomfortable.....3 I am a little uncomfortable with this.....4 I am very uncomfortable with this.....5	
6.6	List 3 ways that you can best describe people from _____. (<i>Site specific: insert name of conflicting community in bordering sub-county as specified on Q1.7 Then write in three responses.</i>)	1. _____ 2. _____ 3. _____	

Part 7: Dispute resolution

Now I'd like to ask you some questions about how disputes are resolved in your community.

#	Questions	Answers (and Coding)	Instructions
7.1	During the past year, how often were disputes in your community resolved so that all sides were satisfied and didn't complain?	Never.....1 Rarely.....2 Sometimes.....3 Most of the time.....4 Always.....5	
7.2	During the past year, how often were disputes in your community resolved peacefully?	Never.....1 Rarely.....2 Sometimes.....3 Most of the time.....4 Always.....5	
7.3	During the past year, who usually resolved disputes between your community and ____? (<i>Site specific: insert name of conflicting community in bordering sub-county as specified on Q1.7. Do not read the list. Let the respondent speak. Circle the first three people/institutions the respondent mentions.</i>)	Elders.....1 Kraal leaders.....2 Peace committees/Joint Monitoring Teams.....3 Women.....4 Youth.....5 Local leaders.....6 Nobody.....7 Don't know.....8 Other (specify).....9	

7.4a	During the past year, have there been any peace dialogues with ____? <i>(Site specific: insert name of conflicting community in bordering sub-county as specified in Q1.7)</i>	Yes.....1 No.....2 Don't know.....3	If No or Don't know, skip to Q7.5
7.4b	If yes, did you personally participate?	Yes.....1 No.....2	If No, skip to Q7.5
7.4c	If yes, what was your role?	Leader.....1 Participant.....2 Other (specify).....3	
7.4d	If yes, who else participated in the peace dialogue? <i>(multiple – circle all that apply)</i>	Elders.....1 Kraal leaders.....2 Peace committees.....3 Women.....4 Youth.....5 Religious leaders.....6 NGOs.....7 Local government.....8 Other (specify).....9	
7.5	How often do local government officials visit your community to discuss topics of conflict and peace?	Never.....1 Rarely.....2 Sometimes.....3 Frequently.....4 Not sure.....5	
7.6	How responsive is the local government to local needs relating to conflict, peace, and reconciliation?	Very responsive.....1 Somewhat responsive.....2 Not at all responsive.....3 Not sure.....4	
7.7a	In the past year, how many peace agreements have taken place between your community and ____? <i>(Site specific: insert name of conflicting community in bordering sub-county as specified in Q1.7)</i>	_____ <i>(Write in number)</i>	If None, skip to Q7.8
7.7b	Do you think these peace agreements are fair?	Never.....1 Rarely.....2 Sometimes.....3	

		Most of the time.....4 Always.....5	
7.8	In the past year, were any peace agreements between your community and _____ violated? <i>(Site specific: insert name of conflicting community in bordering sub-county as specified in Q1.7)</i>	Never.....1 Rarely.....2 Sometimes.....3 Most of the time.....4 Always.....5	
7.9	How hopeful are you about having peace between your community and _____? <i>(Site specific: insert name of conflicting community in bordering sub-county as specified in Q1.7)</i>	Very hopeful.....1 Somewhat hopeful.....2 Hardly hopeful.....3 Not at all hopeful.....4 Not sure.....5	

Conclusion

Thank you very much for your time. Do you have any questions for me?

Annex 8.5 Indonesia Survey

Maluku Economic Recovery Program II Midterm Survey

Part 1: Informed consent

The interviewer should read this aloud.

Hello. My name is _____ and I work with Mercy Corps. Mercy Corps is an international nongovernmental organization that works for peacebuilding and economic development in this region. We are conducting a survey of households and have randomly selected yours. Participation in the survey is voluntary and you are free to decline to answer any or all questions. The results will be kept confidential and will only be used to help Mercy Corps design better programs in this region. This survey usually takes _____ minutes to complete.	
Will you participate in this survey?YesNo
Signature of interviewer	

Part 2: Demographic Information

I'd like to start by learning a little bit about you. Please remember that your responses will be kept confidential.

#	Category	Answers (and Coding)	Instructions
2.1	Sex	male.....1 female.....2	
2.2	Age	17-35.....1 36-45.....2 46-55.....3 55+.....4 decline to respond.....0	
2.3	Education	elementary.....1 junior high.....2 high school.....3 decline to respond.....0	
2.4	Marital Status	married.....1 single.....2 widowed.....3 decline to respond.....0	
2.5	Ethnic Group		
2.6	Religion	Muslim.....1 Protestant.....2 Catholic.....3 other (specify).....4 decline to respond.....0	

Part 3: Livelihoods

Now I'd like to ask you some questions about livelihoods in your community.

#	Questions	Answers (and Coding)	Instructions
3.1	What is your primary source of income?	farming.....1 fishing.....2 driver.....3 civil servant.....4 Becak.....5 craftsman.....6 merchant.....7 carpentry.....8 construction.....9 Ojek.....10 veteran.....11 small business.....12 unskilled labor.....13 none.....14 other (specify).....15 decline to respond.....0	
3.2	Do you get income from any other source? If so, which ones?	_____ _____	Please instruct the participant <i>to list all other sources of income</i>
3.3	How much are your average monthly total earnings from all of these sources of income?	< Rp. 500,000.....1 Rp. 500,000- Rp. 1 million.....2 Rp. 1,1 million - Rp. 3 million.....3 > Rp. 3 million.....4 decline to respond.....0	
3.4	How you compare your financial situation to your peers?	about the same.....1 better off.....2 worse off.....3	
3.5	How would you compare your financial situation to last year?	about the same.....1 better off.....2 worse off.....3	
3.5a	<i>What explains the difference?</i>	_____ _____	
3.6	What agricultural products do you sell?	cacao.....1 spinach.....2 maize.....3 eggplant.....4 cucumber.....5 cassava.....6 sawi.....7 kangkung.....8 fish.....9 coconut oil.....10 other (specify).....11	Please instruct the participant <i>to identify all agricultural products that apply</i>

#	Questions	Answers (and Coding)	Instructions
3.6a	<i>For each product, please list the price you received?</i>	cacao _____ spinach _____ maize _____ eggplant _____ cucumber _____ cassava _____ sawi _____ kangkung _____ fish _____ coconut oil _____ other _____	
3.6b	<i>For each product, please list the amount you sold, on average, per month this past year?</i>	cacao _____ spinach _____ maize _____ eggplant _____ cucumber _____ cassava _____ sawi _____ kangkung _____ fish _____ coconut oil _____ other _____	
3.6c	<i>For each product, please note if your sales have increased, decreased, or stayed the same relative to last year?</i>	cacao _____ spinach _____ maize _____ eggplant _____ cucumber _____ cassava _____ sawi _____ kangkung _____ fish _____ coconut oil _____ other _____	
3.6d	<i>For each product, if there were changes compared to last year, please explain why.</i>	cacao _____ spinach _____ maize _____ eggplant _____ cucumber _____ cassava _____ sawi _____ kangkung _____ fish _____ coconut oil _____ other _____	

#	Questions	Answers (and Coding)	Instructions
3.7	Which communities/groups purchase your products?	_____ _____	Please instruct the participant <i>to list all communities or groups that purchase their products</i>
3.7a	<i>Are any of these communities/groups ones with which you have a history of tension?</i>	yes.....1 no.....2	
3.8	From which communities/groups do you purchase agricultural products?	_____ _____	
3.8a	<i>Are any of these communities/groups with whom you have a history of tension?</i>	yes.....1 no.....2	
3.9	Have you adopted any new livelihood related techniques/skills this past year? If yes...	yes.....1 no.....2	
3.9a	<i>Please list the techniques/ skills you adopted.</i>	_____ _____	
3.9b	<i>Please note from where you the learned the new techniques/ skills.</i>	_____ _____	
3.9c	<i>Please note from whom you learned the new techniques/ skills.</i>	_____ _____	
3.9d	<i>Please note if the new techniques/ skills increased, decreased, or had no impact on your productivity.</i>	_____ _____	
3.9e	<i>Please note how the new techniques/ skills impacted your productivity.</i>	_____ _____ _____ _____	

#	Questions	Answers (and Coding)	Instructions
3.10	Do you have any economic associations that also include members of X community?	yes.....1 no.....2	
3.10a	<i>If yes, please note the type of economic association.</i>	farming association/union.....1 livestock association/union.....2 chamber of commerce/business association...3 loan/microcredit association.....4 other(specify).....5	Please instruct the participant to identify all associations that apply

Part 4: Internal Relations

Now I'd like to ask you some questions to understand how groups within your community interact.

#	Questions	Answers (and Coding)	Instructions
4.1	There are often differences in characteristics between people living in the same village/neighborhood. For example, differences in economic welfare, social status, and ethnic background. There could also be differences in religious or political beliefs or there could be differences due to age and sex. <i>To what extent do any such differences characterize your village and/ or neighborhood?</i>	to a very small extent.....1 to a small extent.....2 not at all.....3 to a large extent.....4 to a very large extent.....5	
4.2	Compared to five years ago, do you think that these differences are now more, less pronounced, or about the same?	more pronounced.....1 less pronounced.....2 about the same.....3	
4.3	In the past 12 months, have people in this village/ neighborhood gotten together to do something for the benefit of the community? If yes...	yes.....1 no.....2	

#	Questions	Answers (and Coding)	Instructions
4.3a	<i>Please describe what was done/ achieved?</i>	_____ _____ _____ _____	
4.3b	<i>Please note if people of different ethnic or religious backgrounds participated and worked together.</i>	_____ _____ _____ _____	
4.4	Compared to last year, do you think that people are more willing or less willing to work together, or has their willingness to work together remained the same?	more willing to work together.....1 less willing to work together.....2 about the same.....3	
4.5	Are there groups of people in this village/ neighborhood who are prevented from or do not have access to		
4.5a	<i>Education/ Schools</i>	yes.....1 no.....2	
4.5b	<i>Health Services/ Clinics</i>	yes.....1 no.....2	
4.5c	<i>Justice</i>	yes.....1 no.....2	
4.5d	<i>Food Security</i>	yes.....1 no.....2	
4.5e	<i>Livelihood Sources</i>	yes.....1 no.....2	
4.6	What are the two most important reasons why people are denied access to these facilities and services?	primary reason_____ secondary reason_____ <i>options include: poverty, gender, age, religion, political affiliation, occupation, education level, ethnicity, and other</i>	Please instruct the participant to select a primary and a secondary reason from the options provided
4.7	In the last month, how many times have you met with people in a public space to talk or to have food or drinks?	_____ _____	

#	Questions	Answers (and Coding)	Instructions
4.7a	<i>Were the people you met mostly of the same or different ethnicity?</i>	same.....1 different.....2	
4.7b	<i>Were the people you met mostly of the same or different religious orientation?</i>	same.....1 different.....2	
4.7c	<i>Were the people you met mostly of the same or different political affiliation?</i>	same.....1 different.....2	
4.7d	<i>Were the people you met mostly of the same or different gender?</i>	same.....1 different.....2	
4.7e	<i>Were the people you met mostly of the same or different village?</i>	same.....1 different.....2	
4.7f	<i>Were the people you met mostly of the same or different age group?</i>	same.....1 different.....2	
4.8	From your close friends, how many do not belong to your own religion?	none.....1 1-2.....2 some.....3 many.....4 most.....5 all.....6 decline to respond.....0	
4.9	In the past year, in what ways have you interacted with local government?	attended a village/neighborhood council or public meeting.....1 met with a politician, called him/her, or sent him/her a letter.....2 notified the authorities about a local problem.....3 administrative needs (specify).....4 other (specify).....5	Please instruct the participant to identify all types of interaction that apply

Part 5: External Relations

Now I'd like to ask you some questions to understand how community interacts with other communities.

#	Questions	Answers (and Coding)	Instructions
5.1	What villages/communities does your community interact with	_____ _____ _____	Please instruct the participant to list all village and/or communities with whom their community interacts

#	Questions	Answers (and Coding)	Instructions
5.2	How do you interact with other communities?	cultural events.....1 religious events.....2 sporting events.....3 trading activity.....4 cacao trading center.....5 livelihood association.....6 borrowing or lending money.....7 employment.....8 other (specify).....9	Please instruct the participant to identify all types of interaction that apply
5.2a	<i>For each type of interaction, please note the name of the event(s).</i>	cultural events _____ religious events _____ sporting events _____ trading activity _____ cacao trading center _____ livelihood association _____ borrowing or lending money _____ employment _____ other _____	
5.2b	<i>For each type of interaction, please note the name of the organizer(s).</i>	cultural events _____ religious events _____ sporting events _____ trading activity _____ cacao trading center _____ livelihood association _____ borrowing or lending money _____ employment _____ other _____	
5.2c	<i>For each type of interaction, please note the name of the other village(s).</i>	cultural events _____ religious events _____ sporting events _____ trading activity _____ cacao trading center _____ livelihood association _____ borrowing or lending money _____ employment _____ other _____	
5.2d	<i>For each type of interaction, please note how often the interaction(s) occurred.</i>	cultural events _____ religious events _____ sporting events _____ trading activity _____ cacao trading center _____ livelihood association _____ borrowing or lending money _____ employment _____ other _____	

#	Questions	Answers (and Coding)	Instructions
5.2e	<i>For each type of interaction, please note if you participated.</i>	cultural events _____ religious events _____ sporting events _____ trading activity _____ cacao trading center _____ livelihood association _____ borrowing or lending money _____ employment _____ other _____	
5.3	Compared to last year, are you now more likely to attend an inter-communal event?	yes.....1 no.....2	
5.3a	<i>If so, please note why.</i>	_____ _____ _____ _____	
5.4	With which communities do you have the most tension?	_____ _____	Please instruct the participant to list all communities with whom their community has considerable tension
5.5	What are the sources of those tensions?	education level.....1 land issue/housing area.....2 farming land.....3 tradition/Adat.....4 economic status.....5 income.....6 village head election.....7 youth group.....8 alcohol-related behavior.....9 other (specify).....10 none.....0	Please instruct the participant to identify all sources of tension that apply
5.6	How, if at all, have your relationships with members of different communities changed over the last year?	better.....1 worse.....2 same/no change.....3	

#	Questions	Answers (and Coding)	Instructions
5.7	For those relationships that have improved, what are the benefits to you?	<hr/> <hr/> <hr/> <hr/>	
5.8	For those relationships that have gotten worse, what have been the impacts to you?	<hr/> <hr/> <hr/> <hr/>	
5.9	Please indicate your level of agreement with the following statements.		
5.9a	<i>I would use kiosks/ markets/ stalls/ shops run by people from other communities.</i>	strongly agree.....1 agree.....2 neutral.....3 disagree.....4 strongly disagree.....5	
5.9b	<i>I would, without hesitation, start a business with a member of different community if the economic advantages were clear.</i>	strongly agree.....1 agree.....2 neutral.....3 disagree.....4 strongly disagree.....5	
5.9c	<i>I am more cautious with my finances, merchants, and clients that come from other communities.</i>	strongly agree.....1 agree.....2 neutral.....3 disagree.....4 strongly disagree.....5	
5.9d	<i>I prefer to work with customers and merchants from my own community.</i>	strongly agree.....1 agree.....2 neutral.....3 disagree.....4 strongly disagree.....5	
5.9e	<i>When I am invited to a party by someone from my religion, village, ethnicity, and/ or region, I generally attend.</i>	strongly agree.....1 agree.....2 neutral.....3 disagree.....4 strongly disagree.....5	
5.9f	<i>When I am invited to a party by someone from a different religion, village, ethnicity, and/ or region, I generally attend.</i>	strongly agree.....1 agree.....2 neutral.....3 disagree.....4 strongly disagree.....5	

#	Questions	Answers (and Coding)	Instructions
5.9g	<i>I feel comfortable letting my children play in a house of a family from this community</i>	strongly agree.....1 agree.....2 neutral.....3 disagree.....4 strongly disagree.....5	
5.9h	<i>I feel comfortable letting my children play in a house of a family from a different community</i>	strongly agree.....1 agree.....2 neutral.....3 disagree.....4 strongly disagree.....5	
5.9i	<i>I feel comfortable sharing your experiences in the conflict with people of other religious groups</i>	strongly agree.....1 agree.....2 neutral.....3 disagree.....4 strongly disagree.....5	
5.9j	<i>I believe the government is fair to all people</i>	strongly agree.....1 agree.....2 neutral.....3 disagree.....4 strongly disagree.....5	
5.9k	<i>I believe the government is a good local partner</i>	strongly agree.....1 agree.....2 neutral.....3 disagree.....4 strongly disagree.....5	
5.10	What factors do you take into account when deciding where to shop?	price _____ location (proximity) _____ variety of items _____ shop owners' religion _____ shop owners' ethnicity _____ shop owners' village _____ accept credit (pay later) _____ other (specify) _____	Please instruct the participant to rank these factors from most to least important
5.11	On a scale of 1 to 5 where 1 means a very small extent and 5 means a very great extent, how much do you trust the people in the following categories?		
5.11a	<i>People from your ethnicity</i>	to a very small extent.....1 to a small extent.....2 neither small nor great extent.....3 to a great extent.....4 to a very great extent.....5	
5.11b	<i>People from other ethnicities</i>	to a very small extent.....1 to a small extent.....2 neither small nor great extent.....3 to a great extent.....4 to a very great extent.....5	

#	Questions	Answers (and Coding)	Instructions
5.11c	<i>People from your religion</i>	to a very small extent.....1 to a small extent.....2 neither small nor great extent.....3 to a great extent.....4 to a very great extent.....5	
5.11d	<i>People from other religions</i>	to a very small extent.....1 to a small extent.....2 neither small nor great extent.....3 to a great extent.....4 to a very great extent.....5	
5.11e	<i>People from your region/ community</i>	to a very small extent.....1 to a small extent.....2 neither small nor great extent.....3 to a great extent.....4 to a very great extent.....5	
5.11f	<i>People from other regions</i>	to a very small extent.....1 to a small extent.....2 neither small nor great extent.....3 to a great extent.....4 to a very great extent.....5	
5.11g	<i>Adat leaders</i>	to a very small extent.....1 to a small extent.....2 neither small nor great extent.....3 to a great extent.....4 to a very great extent.....5	
5.11h	<i>District-level House of Representatives</i>	to a very small extent.....1 to a small extent.....2 neither small nor great extent.....3 to a great extent.....4 to a very great extent.....5	
5.11i	<i>Provincial-level House of Representatives</i>	to a very small extent.....1 to a small extent.....2 neither small nor great extent.....3 to a great extent.....4 to a very great extent.....5	
5.11j	<i>Provincial-level government</i>	to a very small extent.....1 to a small extent.....2 neither small nor great extent.....3 to a great extent.....4 to a very great extent.....5	
5.11k	<i>District-level government</i>	to a very small extent.....1 to a small extent.....2 neither small nor great extent.....3 to a great extent.....4 to a very great extent.....5	
5.11l	<i>Sub-district-level government</i>	to a very small extent.....1 to a small extent.....2 neither small nor great extent.....3 to a great extent.....4 to a very great extent.....5	

#	Questions	Answers (and Coding)	Instructions
5.11m	<i>Village-level government</i>	to a very small extent.....1 to a small extent.....2 neither small nor great extent.....3 to a great extent.....4 to a very great extent.....5	
5.12	Do you think, over the last year, the level of trust between this village and neighboring villages has gotten better, worse, or stayed about the same?	better.....1 worse.....2 same/no change.....3	

Part 6: Stability/Security

Now I'd like to ask you some questions about peace and security in your village.

#	Questions	Answers (and Coding)	Instructions
6.1	In relation to levels of peace, where does your village belong?	very peaceful.....1 somewhat peaceful.....2 neither peaceful nor violent.....3 somewhat violent.....4 very violent.....5 do not know.....0	
6.2	What consequences, if any, do you fear if fighting resumes?	_____ _____ _____ _____	
6.2a	<i>How might conflict affect your financial situation specifically?</i>	_____ _____ _____ _____	
6.3	Do you feel safe in the following locations in your village?		Please state the following: <i>“Next I am going to list a number of different places. I would like you to tell me if you feel safe in each of these places. Please answer yes or no, and please explain why.”</i>
6.3a	<i>School</i>	yes.....1 no.....2 reason _____ _____	

#	Questions	Answers (and Coding)	Instructions
6.3b	<i>Place of worship</i>	yes.....1 no.....2 reason_____	
6.3c	<i>Market</i>	yes.....1 no.....2 reason_____	
6.3d	<i>Police Station</i>	yes.....1 no.....2 reason_____	
6.3e	<i>Government Office</i>	yes.....1 no.....2 reason_____	
6.3f	<i>Port</i>	yes.....1 no.....2 reason_____	
6.3g	<i>Bus Terminal</i>	yes.....1 no.....2 reason_____	
6.3h	<i>Hutan, Kebun, Latah, and/or Pertanian</i>	yes.....1 no.....2 reason_____	
6.3i	<i>Other (specify)</i>	yes.....1 no.....2 reason_____	

#	Questions	Answers (and Coding)	Instructions
6.4	Do you feel safe in the following locations in other villages?		Please state the following: <i>“Next I am going to list a number of different places. I would like you to tell me if you feel safe in each of these places. Please answer yes or no, and please explain why.”</i>
6.4a	<i>School</i>	yes.....1 no.....2 reason_____	
6.4b	<i>Place of Worship</i>	yes.....1 no.....2 reason_____	
6.4c	<i>Market</i>	yes.....1 no.....2 reason_____	
6.4d	<i>Police Station</i>	yes.....1 no.....2 reason_____	
6.4e	<i>Government Office</i>	yes.....1 no.....2 reason_____	

#	Questions	Answers (and Coding)	Instructions
6.4f	<i>Port</i>	yes.....1 no.....2 reason_____	
6.4g	<i>Bus Terminal</i>	yes.....1 no.....2 reason_____	
6.4h	<i>Hutan, Kebun, Latah, and/ or Pertanian</i>	yes.....1 no.....2 reason_____	
6.4i	<i>Other (specify)</i>	yes.....1 no.....2 reason_____	
6.5	To your knowledge, have there been any incidents of violence in your village in the last 3 months? If yes...	yes.....1 no.....2	If the participant answers, "no," please move on to question 6.6.
6.5a	<i>About how many incidents occurred?</i>	_____ _____	
6.5b	<i>Please describe what happened.</i>	_____ _____ _____ _____	
6.5c	<i>Please describe the causes of the violence, if known.</i>	_____ _____ _____ _____	
6.5d	<i>About how many people were involved?</i>	_____ _____	

#	Questions	Answers (and Coding)	Instructions
6.5e	<i>Have any differences between groups within the community ever led to violence?</i>	<hr/> <hr/> <hr/> <hr/>	
6.6	Are there any situations in which you think violence is justified? If so, please describe which situations and why.	<hr/> <hr/> <hr/> <hr/> <hr/>	
6.7	Compared to last year, has the level of violence in this village/neighborhood increased, decreased, or stayed about the same?	increased.....1 decreased.....2 same/no change.....3	

Conclusion

Thank you for your time and willingness to respond. Is there anything else you would like me to know before we conclude?

Annex 8.6 Indonesia Disputes & Dispute Resolution

Participatory Assessment Tool: Disputes & Dispute Resolution

Description

Participants identify the actors involved in local dispute resolution, identify common types of local disputes, and analyze how effective actors are in resolving local disputes. The tool combines open-ended discussion questions with several techniques for collecting quantitative data – including proportional piling, ranking, and scoring – in order to generate rich contextual data as well as benchmarks for monitoring and evaluation.

Objectives

- To identify the actors involved in local dispute resolution and evaluate how effective they are
- To identify common types of local conflict
- To establish benchmarks (e.g., baseline data) regarding the incidence of conflict and conflict resolution

Key Questions

- What types of conflict occur in the community?
- What strengths and assets do the community use to maintain peace?
- How frequently do these conflicts occur?
- How do community members define successful conflict resolution?
- How do community members define peace?
- Do leaders play a role in bringing different groups within the community together?
- Have there been cases where leaders encouraged divisions between groups?
- What role do leaders play in resolving disputes as they arise?
- Who resolves disputes in the community?
- How effective are these actors at resolving disputes? Why?
- Which types of conflict have the most negative impact on the community?
- Which types of conflict are most difficult to resolve? Why?

Key Indicators

- % change in # of people who think violence will lead to economic loss
- % change in number of disputes that are peacefully resolved
- % change reported incidents of violence
- % change in severity of violent incidents
- % change in sources of tensions
- % change in the number of people who support violence
- # of leaders, youth, and women participating in peace skills/dispute resolution training

Preparation

Make sure that you have all necessary materials. Arrange a meeting location with adequate space to facilitate the discussion where participants are unlikely to be disturbed by others.

Materials: flip chart, markers, about 150 counters (beans, stones, etc.), guide, data entry form, digital camera.

Methodology

1. Introduction

Thank the participants for coming. Explain that you would like to understand how different people and institutions in the community resolve disputes and that you would like to understand what contributes to building peace in the community.

2. Define “Peace” and Define “Dispute”

Ensure that the group has a common understanding of peace and of the word “dispute.” Explain that we would like to understand what peace means to the community.

- a. First, ask the group, “How do you define the word ‘peace?’”
- b. Ask the group to describe what happens in their community when there is peace. Encourage discussion by asking how busy are the markets or how do people interact.

3. List the types of disputes

Explain that you would now like to understand what types of disputes occur within the community and between communities.

- a. Ask the group, “How do you define the word ‘dispute?’”

Once the group has come to agreement, ask them to list the types of disputes that occur within their community. Write the list on a flip chart, using pictures to represent each type of dispute. Then ask the community to list the types of disputes that happen between their community and other communities. Write the list on the first flip chart, using pictures to represent each type of dispute. Once the group has listed the types of dispute, prioritize no more than 5 types of dispute.

As the facilitator, if the community has not raised land or natural resources as types of dispute, ask participants if it is a type of dispute that impacts the community.

Now draw the symbol representing each type of dispute that has been prioritized in a column on the left-hand side of a flip chart. Draw lines separating each type of dispute, so that you have several rows dividing the flip chart.

4. Rank the frequency and impact of each type of dispute

Tell the group you’d like to know which types of disputes occur most frequently. Give the group 20 counters (beans, stones, etc.). Ask them to allocate the counters between the various types of disputes. The greatest number of counters should be placed next to the most frequent type of dispute. An equal number of counters should be placed next to types of disputes that occur with the same frequency. Confirm that you understand the ranking from the most frequent to the least frequent type of dispute. The note taker should write down this ranking, with 1 being the most frequent type of dispute. The note taker should also write the number of counters assigned to each type of dispute.

- a. Ask the group to estimate the number of times each type of dispute occurred in the last 3 months.
- b. Ask the group, of the disputes that occurred, how many were resolved peacefully.
- c. Ask the group if violence ever occurred because of a dispute.

Explain to the group that you would like to understand what might limit dispute resolution.

- d. Ask the group, “Are there situations where you think violence is justified? If so, what situations? Why?” You may probe further by asking questions such as “What if your property or livelihood is threatened?”

Remove the counters from the matrix, and tell the group you’d like to know which types of disputes impact their lives most negatively. Give the group the 20 counters again and ask them to allocate the counters between the various types of disputes. The greatest number of counters should be placed next to the type of dispute that has the most negative impact on their lives. An equal number of counters should be placed next to types of disputes that have an equal impact on their lives. Confirm that you understand the ranking from the type of dispute that has the most negative impact to the type of dispute that has the least negative impact.

The note taker should write down this ranking, with 1 being the type of dispute with the most negative impact. The note taker should also write the number of counters assigned to each type of dispute.

5. List actors and institutions who resolve disputes

Tell the group you would now like to understand which actors and institutions resolve disputes in their community. First ask the group to describe, “When a dispute arises, how does your community usually respond?”

Then, tell them you would like them to list all the actors or institutions that resolve disputes. Explain that they can name types of people or institutions, whether traditional, official, formal, or informal. Give the group a few minutes to brainstorm as a group and take note of the discussion among participants. Remind participants not to list names of individual people and that we would like to understand the type of actors or institutions that help resolve disputes.

Once the group has developed a list, ask the group to prioritize no more than 5 actors or institutions. Put a check mark beside those 5 actors. Next, list these five actors or institutions on the top of your chart. Ask a participant to draw a symbol to represent each of the five selected actors or institutions.

Then draw each of the prioritized actor’s symbol across the horizontal top of a new flip chart. Draw lines separating each actor/institution, so that you have several columns dividing the flip chart.

At this point you will have a matrix that looks like this:

Disputes	Actor A	Actor B	Actor C	Actor D	Actor E
Type A					
Type B					
Type C					
Type D					
Type E					

6. Determine who resolves each type of dispute and who is most successful in dispute resolution

Tell the group that you’d like to understand who usually resolves the different types of disputes and how successful they are. For each type of dispute, give the group 20 counters and ask the following questions.

- a. Ask, “Who do people in your community usually go to in order to resolve this type of dispute?” Tell the group to place a counter in the column representing the actor or actors they go to in order to resolve that type of dispute.
- b. Using the remaining counters, ask the group to indicate which actors are most successful at resolving that type of dispute by allocating counters between the actors. The greatest number of counters should be placed in the column representing the actor who is most successful at resolving that type of dispute. Confirm that you understand the ranking of actors from the most to the least successful at resolving that type of dispute. The note taker should write down this ranking, with 1 being the actor who is most successful at resolving that type of dispute. The note taker should also write the number of counters assigned to each actor in that row.
- c. Ask, “How do you know that this type of dispute has been successfully resolved?” Probe on this question. For example, how does behavior change when a dispute has been resolved? What are people able to do once a dispute has been resolved that they may not have been able to do previously?

- d. Ask the group why they think each the most successful actor at resolving that type of dispute is the most successful. Then ask the group why they think the least successful actor for resolving that dispute is the least successful.

Repeat this process for each type of dispute. Use a new set of 20 counters for each type of dispute.

7. Evaluate the success of dispute resolution mechanisms

Referring to the previous discussion, tell the group you'd like to understand who is overall most successful at resolving disputes. Give the group another 20 counters. Ask them to allocate the counters between the various actors, piling the counters next to the symbols on the flip chart representing each one. The greatest number of counters should be placed next to the actor that is most successful at dispute resolution. An equal number of counters should be placed next to actors that are equally successful at dispute resolution.

Once the piling is complete, ask the participants to explain it. Probe to understand why they consider some actors more successful than others at dispute resolution.

Confirm that you understand the ranking of actors from the most to the least successful at dispute resolution. The note taker should write down this ranking, with 1 being the actor who is overall most successful at resolving disputes. The note taker should write the number of counters assigned to each actor in that row.

8. What prevents conflict from being resolved?

Referring to the previous discussion, ask the group which types of disputes are difficult to resolve. Identify 3 types of disputes that are most difficult to resolve. Place a counter next to each of these types of disputes.

- a. Ask them to explain why they think each of these types of disputes is difficult to resolve.
- b. Ask them what needs to happen in order to promote the resolution of these types of disputes.
- c. Ask, "What can your community do to create peace in your community or between communities?"

9. How do you know when conflict is resolved?

- a. Ask the group, "How they will know when there is peace between these communities?"
- b. "What does peace look like?"
- c. Ask them, "Does your community feel that there is peace now?"
- d. Ask the group, "What issues, if any, do you worry might threaten the current peace?"
- e. Ask, "Is your economic wellbeing better off in times of peace?"

10. Strengths and Assets

Explain to the group that you would like to understand what other resources the community has to resolve disputes.

- a. Ask, "Aside from the actors and institutions you have described, are there other ways to bring about peace in your community?"
- b. Ask, "How does your community maintain peace?"

Ask the group to make a list of all the strengths and assets it has within the community to resolve conflict. Of these, ask the group to list the top five most important assets.

- c. Ask the group, "In the past year, which of these strengths and assets did the community use to resolve disputes?"

11. Conclusion

Thank the participants for their time and ask them whether they have any questions. Ask them if there is anything else they would like to say or discuss. Remind them that you will return to share the results of the focus group with them.

Annex 8.7 Indonesia Scored Community Relationship Mapping

Scored Community Relationship Mapping MERP II Modifications

Description

Scored Community Relationship Mapping explores the nature of the relationship between conflicting communities and key external actors who influence that relationship. Participants identify approximately five key actors who influence stability within and across communities. After mapping the relationships between key actors, participants are asked a number of quantitative and qualitative questions about each relationship. In addition, participants are asked to describe the types of social and economic interactions between the conflicting communities.

Objectives

- To identify communities and key actors
- To describe the relationships between these actors, including social and economic interactions
- To explore the relationship between conflict and social and economic interactions
- To establish benchmarks (e.g., baseline data) regarding community tensions and types of interactions between communities

Key Questions

- Who are the key actors at the community level who influence social cohesion?
- What are relationships between the key actors like?
- How do communities define a good and bad relationship?
- How often do community members interact with people from conflicting communities?
- What types of social and economic interactions do community members have with people from conflicting communities?
- What impact do social relationships have on peace and stability?
- What type of social and economic interactions are associated with good and bad relationships?

Indicators:

- % change in willingness to interact economically between communities
- % change in volume of trade with other community
- % increase in inter-communal cooperative activities or events over duration of project
- % change in # of people who benefit from peaceful relations from those they were in conflict with in the past
- % change in # of people who think violence will lead to economic loss
- % change in levels of trust between members of divided communities
- % change in frequency of social interaction
- % change in types of social interaction
- % of people who positively assess the quality of the relationship with the government or the community
- % change in willingness to interact socially between communities
- % change in # of ways community and district level government cooperate
- % change in negative characterization of other groups
- % change in sources of tension between groups

- % change in frequency of economic interaction
- % change in the # of people who place a higher value on cooperation than on conflict

Preparation

Make sure that you have all necessary materials. Arrange a meeting location with adequate space to facilitate the discussion where participants are unlikely to be disturbed by others.

Materials: flip chart, markers, guide, data entry form, digital camera

Time

2-3 hours

Methodology

1. Introduction

Thank the participants for coming. The note taker counts the number of participants, disaggregating by men, women, and male youth (ages 17-35). Introduce yourself. Explain that the purpose of the focus group is to understand what contributes to peace within both their community and the region. Explain the purpose of the discussion is to better understand both positive and negative aspects of relationships within the community and between neighboring communities.

Explain that in the first part of the session you will help the group draw a visual representation of this discussion on the flip chart (called a “relationship map”). In the second part of the session you will facilitate a discussion of the map with the group so that everyone can better understand the nature of relationships and interactions. Remind the participants that there are no right or wrong responses; we are interested in their perception of the situation.

2. Identify communities/groups

There are often differences in characteristics between people living in the same village/neighborhood. For example, differences in economic welfare, social status, and ethnic background. There could also be differences in religious or political beliefs, or there can be differences due to age or sex. These differences may bring people together or occasionally be a source of tension.

- a. Who are the different groups in your community?
- b. Who are the different groups in neighboring communities?

3. Identify key actors

Explain to the group that you would like to understand which actors or groups influence social cohesion. Ask the group to brainstorm a list of key actors that influence tension both positively and negatively. These actors might include government officials, other communities, religious institutions, etc. Encourage the group to brainstorm both internal and external actors. These actors/groups might include youth, elders, or traditional leaders. The facilitator will record the suggested actors on an empty flip chart.

Once the group has brainstormed a list of key actors, ask them to select the **five actors** who have the most influence on relationships and social cohesion. Have the group select a picture to represent each group, including their own village. The picture should be neutral (e.g., maize rather than a machete) in order to avoid worsening negative stereotypes.

As the facilitator, draw six large circles on the map. Write the name of the communities, actors, or institutions in each circle and ask a participant to draw the image for each corresponding group in each of the circles. The note taker will make the same list in the notes and will record how each group is represented. Remind participants that the most relevant actors are not necessarily the most powerful or the ones with the most resources. Repeat that you want to better understand the relationship between these actors.

4. Illustrate relationships between key actors

Tell the participants that you would now like to talk about the relationships between these key actors. For each pair of key actors, you will ask the group to rate the relationship as very good, good, neutral, bad, or very bad (see Question 1). If you have 5 key actors, you will talk about 10 different relationships. Begin with the target community (the community where you are conducting the focus group). Assign numbers to each of the relationship lines as you go.

Question 1a.: Ask, “Would you describe the relationship between A and B as very good, good, neutral, bad, or very bad?”

Using the following key, ask a participant to draw the type of line that represents the nature of the relationship between the two circles that represent those two communities. The note taker should use the following table to determine how to assign relationship scores to each relationship. These scores will be entered in the data entry form.

Type of Relationship	Type of Line	Relationship Score
Very Bad Relationship		-2
Bad Relationship		-1
Neutral Relationship		0
Good Relationship		1
Very Good Relationship		2

After rating and illustrating each relationship, the community relationship map should look like this:

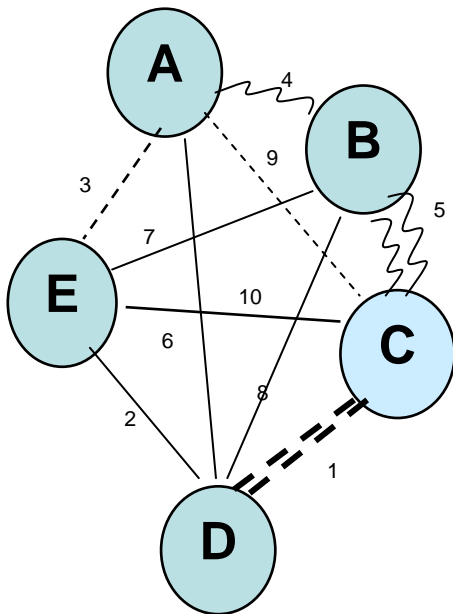

You should emphasize that the map is only a symbolic representation of how actors and groups are connected. Therefore it does not have to represent the geographic location of people, only how they are

related. Confirm with participants that the map is correct and that the lines accurately represent the relationships between key actors.

5. Describe relationships between key actors

Ask the following series of questions about each relationship. You should ask all of the questions about a given relationship before moving on to the next relationship.

Question 2: Ask, “Why do you describe the relationship between A and B as good or bad?”

The note taker should listen and write down comments related to:

- How participants define a good or bad relationship;
- Types of activities that foster a positive or negative relationship (e.g., markets, shared religious institutions, work, other);
- Sources of tension (e.g., water, markets, roads, resources, aid, other);
- Recent events that illustrate that the relationship is good or bad.

Question 3: Ask, “In the last year, how has this relationship changed?” “What accounts for this change?”

The note taker should note the score for direction of change and note all listed causes of change.

Relationship Change	Score
Improved, a lot	5
Improved, somewhat	4
Stayed the same	3
Got somewhat worse,	2
Got much worse	1

Question 4a: Ask, “What type of interactions are there between A and B?”

The purpose of this question is to explore both social and economic interactions between the key actors. The note taker should record this conversation carefully, noting both social and economic interactions as well as whether interactions are positive or negative. If the group has a hard time thinking of interactions, the facilitator can probe by asking about specific types of interactions.

Social interactions may include:

- going to the same church or mosque;
- attending the same social events such as marriages, funerals, celebrations, etc.;
- intermarriage;
- joint membership in community groups, etc.;
- going to the same school or health center.

Economic interactions may include:

- buying or selling goods to each other;
- frequenting the same markets;
- working for someone from the other community;
- employing a member of the other community, including to watch one’s animals or work in one’s field;
- giving or receiving a loan.

Question 4b: Ask, “How often do A and B typically interact in one month: never, less than one time per month, one-two times per month, weekly, or daily?”

The note taker should use the following table to determine how to assign interaction scores to each relationship. These scores will be entered in the data entry form.

Frequency of Interaction	Interaction Score
never	1
less than 1 time per month	2
1-2 times per month	3
weekly	4
daily	5

Question 4.c: Ask, “Should the frequency of interactions between A and B increase, stay the same, increase or decrease?” “What benefits do you receive from interaction?” “What economic benefits do you receive from interaction?”

<u>Perceptions:</u>	<u>Interactions</u>	<u>Score</u>
<u>Should</u>		
<u>Increase</u>		1
<u>Stay the same</u>		0
<u>Decrease</u>		-1

Question 5: Ask, “How do A and B usually resolve disputes?”

The note taker should use the following table to determine how to assign dispute resolution scores to each relationship. These scores will be entered in the data entry form.

Dispute Resolution Method	Dispute Resolution Score
Physical fighting	1
Verbal argument	2
Traditional mediation	3
Formal government mediation	4
Discussion and dialogue	5

Question 6: Ask, “Will your community incur economic losses if fighting breaks out?”

<u>Economic losses</u>	<u>Score</u>
<u>Yes, Significant economic loss expected</u>	5
<u>Yes, Some economic loss expected</u>	4
<u>Livelihoods unaffected</u>	3
<u>No, Some economic gain expected</u>	2
<u>No, Significant economic gain expected</u>	1

Question 7: Ask, “What would be needed to improve this relationship?”

Question 7.b: Ask, “What activities/influences help build trust between A and B?”

6. Conclusion

Thank the participants for their time and ask them whether they have any questions.

Take a picture of the map with a digital camera. Make sure that the information is legible.

Annex 8.8 Uganda/Ethiopia Conflict & Resource Mapping

Participatory Assessment Tool: Conflict & Resource Mapping

This tool was used in Uganda. A similar tool was used in Ethiopia.

Description

Participants draw a map of the area affected by the conflict. This mapping allows for analysis of relationships between resource use, economic activities, conflict, and group interactions.

Objectives

- To identify local resources that the community uses or needs/wants to use but can't access
- To explore the relationship between local resources and conflict
- To establish benchmarks (e.g., baseline data) regarding resource use and the impact of conflict on movement

Key Questions

- What resources does the community use? Where are these resources located?
- What resources does the community need/want to use but can't access? Where are these resources located?
- Is there agreement over the use of resources used by multiple communities, or are these shared resources a source of tension?
- How does conflict and insecurity impact movement and access to resources?
- Where have conflict incidents occurred?
- What relationships exist between conflict and the location of boundaries, settlements, and livelihoods-related resources?

Key Indicators

- % decrease in reported incidents of violence
- % increase of movement in previous "no-go areas"
- % change in availability of and access to economic inputs/resources

Preparation

Make sure that you have all necessary materials. Arrange a meeting location with adequate space to facilitate the discussion where participants are unlikely to be disturbed by others.

Materials: flip chart, markers, guide, data entry form, digital camera

Methodology

1. Introduction

Thank the participants for coming. Explain that you would like to learn about resources in the area that the community uses or needs/wants to use but can't access. Explain that you'd like them to draw a picture showing where these resources are located, considering resources inside their parish, sub-county, and district as well as in other areas if that is relevant for them. Tell them that you are interested in their perceptions, not in an accurate map of the area.

2. Develop the map key

Explain to the group that there are several elements that they should include on the map. Make a key of these elements on a flip chart. Ask the group to choose a symbol or simple picture to represent each element. Encourage participation by asking participants to draw the picture for the key. The facilitator can draw the key if the participants have a difficult time. The key symbols should be very simple and different from each other.

The map should include the following elements:

1. Main human settlements
2. Main roads
3. Kraals
4. Water points and rivers
5. Grazing areas
6. Farmland
7. Forestland
8. Markets and marketing routes
9. Schools
10. Health centers

Review the key with the participants and confirm that they know what each symbol stands for by pointing at each symbol and asking them what it means.

Draw a large rectangle on the paper that fills up most of the page but provides a margin on each side. (This will enable the group to indicate what communities and resources neighbor theirs.) Help to start the map by drawing 2-3 major landmarks on the flip chart, such as main roads, cities, rivers, or a mountain. Clarify that you want them to draw the area including all of the resources that they either use or need/want to use but can't access.

Emphasize to group members that accuracy is not the point of the exercise, and explain that all group members should participate and come to consensus on key features of the picture, even if one person is designated to draw it. Answer any questions group members have.

After all questions have been answered, explain that you will leave the group alone to draw the map and return in 30 minutes.

3. Check in

Return in 30 minutes to check on the group's project. Ask about any challenges that the group has encountered or see if participants have any questions. Allow more time if the group needs it.

4. "Interview the map"

After all group members are satisfied that the map is finished, ask the group to "walk you through" the map. Ask the following questions:

1. Ask the group to present the map. The note taker will take careful notes, linking participants' comments to different features of the map. The note taker should pay particular attention to any mention of tension or conflict.
2. Access to resources: Clarify whether each resource is already used by the community or is a resource that they are unable to access. Confirm whether there are other resources outside their community that they use or need/want to use but can't access. Number each resource if necessary to help the note taker track this information.
3. Shared resources: Ask "Which resources are also used by other communities?" Number each shared resource and note which communities share it. For each shared resource, ask whether the

communities are in agreement about how the resource is used and if the resource is a source of tension.

4. Insecure areas: Ask whether there are any insecure areas that the group doesn't go to due to fear of violence. This question will provide information about the extent of no-go areas due to insecurity, defined as areas that people don't go to because they are afraid of violence. Locate any insecure areas on the map. Ask the group to explain. Describe the areas of insecurity, including why they are considered insecure.
5. Buffer zones: Ask whether there are any areas that the group doesn't go to because community/government leaders have agreed to close the area in order to avoid conflict. This question will provide information about the extent of no-go areas that are buffer zones, defined as areas that people are not allowed to go to because leaders have agreed to close the area in order to avoid conflict. Locate any buffer zones on the map. Ask the group to explain these areas, including why the buffer zones were created.
6. Conflict incidents: Ask whether any conflict incidents have occurred in last year. Explain what a conflict incident is: a violent event that is linked to the community conflict and may include beating, killing, burning of houses or fields, rape, abduction, etc. Locate any conflict incidents on the map. Ask the group to explain what happened during each incident.

For each conflict incident, also ask, "What economic resources did the community lose?"

Ask, "In general, when violence occurs with the conflicting community, does your community experience economic losses? What are the economic costs of conflict that your community experiences?"

7. Community territory: Ask the group to describe the area that they perceive as belonging to them, including areas that they may have been displaced from and areas where they are now living. The facilitator or a participant should draw a line around this area.
8. Administrative borders: If it has not yet become clear, ask the group to clarify administrative boundaries. Don't ask directly about borders. Instead, ask them to show you where the different sections (e.g. districts/sub-counties, etc.) are located. The facilitator or a participant can draw these lines on the map, making it clear that these are not formal borders but are just symbolic to help you remember where things are located.
9. Patterns: Ask participants whether they see any patterns or linkages between different features of the map. Are there any relationships between the location of conflict incidents/no-go areas and other features, including boundaries, livelihoods resources, etc.?
10. Livelihoods: Ask the participants, "Compared to one year ago, have livelihoods opportunities increased, decreased, or stayed the same? How does this relate to conflict?" The note taker should write down all changes that respondents mention, i.e. whether livelihoods opportunities have gone up and down several times throughout the year.

Add any legends that may be necessary to understanding the map in the future.

5. Conclusion

Thank the participants for their time and ask them whether they have any questions.

Take a picture of the map with a digital camera. Make sure that the information is legible.

Annex 8.9 Uganda/Ethiopia Scored Community Relationship Mapping

Participatory Assessment Tool: Scored Community Relationship Mapping

This tool was used in Uganda. A similar tool was used in Ethiopia.

Description

Scored Community Relationship Mapping explores the nature of the relationship between conflicting communities and key external actors who influence that relationship. Participants identify approximately five key actors who influence a given conflict between their community and another community. After mapping the relationships between key actors in the conflict, participants are asked a number of quantitative and qualitative questions about each relationship. In addition, participants are asked to describe the types of social and economic interactions between the conflicting communities.

Objectives

- To identify the communities and key external actors involved in a given conflict
- To describe the relationships between these actors, including social and economic interactions
- To explore the relationship between conflict and social and economic interactions
- To establish benchmarks (e.g., baseline data) regarding community tensions and types of interactions between conflicting communities

Key Questions

- Who are the key actors at the community level who influence the conflict?
- What are relationships between the key actors like?
- How do communities define a good and bad relationship?
- How often do community members interact with people from conflicting communities?
- What types of social and economic interactions do community members have with people from conflicting communities?
- What type of social and economic interactions are associated with good and bad relationships?

Key Indicators

- a. % change in negative relationships between divided communities
- b. % increase of general economic interaction with members of the other community

Preparation

Make sure that you have all necessary materials. Arrange a meeting location with adequate space to facilitate the discussion where participants are unlikely to be disturbed by others.

Materials: flip chart, markers, guide, data entry form, digital camera

Time

2-3 hours

Methodology

1. Introduction

Thank the participants for coming and introduce yourself. Explain that due to Mercy Corps' previous work in the area, we understand that there has been a misunderstanding between the community and another

community. Specify the name of the community and confirm that this is correct. Explain that the purpose of the focus group is to understand both positive and negative aspects of the relationship between these communities.

Explain that in the first part of the session you will help the group draw a visual representation of this discussion on the flip chart (called a “relationship map”). In the second part of the session you will facilitate a discussion of the map with the group so that everyone can better understand the nature of these relationships and the interactions between these communities. Remind the participants that there are no right or wrong responses; we are interested in their perception of the situation.

2. Draw the conflicting communities on the map

Draw two circles on a blank flip chart representing the two conflicting communities (draw three circles if you are dealing with a conflict between three communities). Put the name of the communities in a circle and ask the group to choose a picture that represents each community. The picture should be neutral (e.g., maize rather than a machete) in order to avoid worsening negative stereotypes. Draw this picture inside the circle. In order to encourage participation, you can ask a participant to draw on the flip chart. Repeat that you want to better understand the relationship between these communities.

3. Identify key external actors

Brainstorm a list of key external/other actors that influence the relationship between the conflicting communities both positively and negatively. External actors might include government officials, other communities, religious institutions, etc. Do not include internal actors who are members of the conflicting communities, such as youth, elders, or traditional leaders. The facilitator will record the suggested actors on an empty flip chart, using pictures to represent each group. Again, you can ask a participant to draw the pictures in order to encourage participation. The note taker will make the same list in the notes and will record how each group is represented.

Once the group has brainstormed a list of key external actors, ask them to select the two or three external actors who have the most influence on the relationship between the conflicting communities for a total of five key actors on the community relationship map. If there are two conflicting communities, the group can select up to three key external actors; if there are three conflicting communities, the group can select up to two key external actors. Remind participants that the most relevant actors are not necessarily the most powerful or the ones with the most resources.

Ask a participant to draw circles on the community relationship map representing the selected key external actors with a picture representing each actor in the middle of the circle.

4. Illustrate relationships between key actors

Tell the participants that you would now like to talk about the relationships between these key actors. For each pair of key actors, you will ask the group to rate the relationship as very good, good, neutral, bad, or very bad (see Question 1). If you have 5 key actors, you will talk about 10 different relationships. Begin with the target community (the community where you are conducting the focus group). Assign numbers to each of the relationship lines as you go.

Question 4: Ask, “Would you describe the relationship between A and B as very good, good, neutral, bad, or very bad?”

Using the following key, ask a participant to draw the type of line that represents the nature of the relationship between the two circles that represent those two communities. The note taker should use the following table to determine how to assign relationship scores to each relationship. These scores will be entered in the data entry form.

Type of Relationship	Type of Line	Relationship Score
Very Bad Relationship		-2
Bad Relationship		-1
Neutral Relationship		0
Good Relationship		1
Very Good Relationship		2

After rating and illustrating each relationship, the community relationship map should look like this:

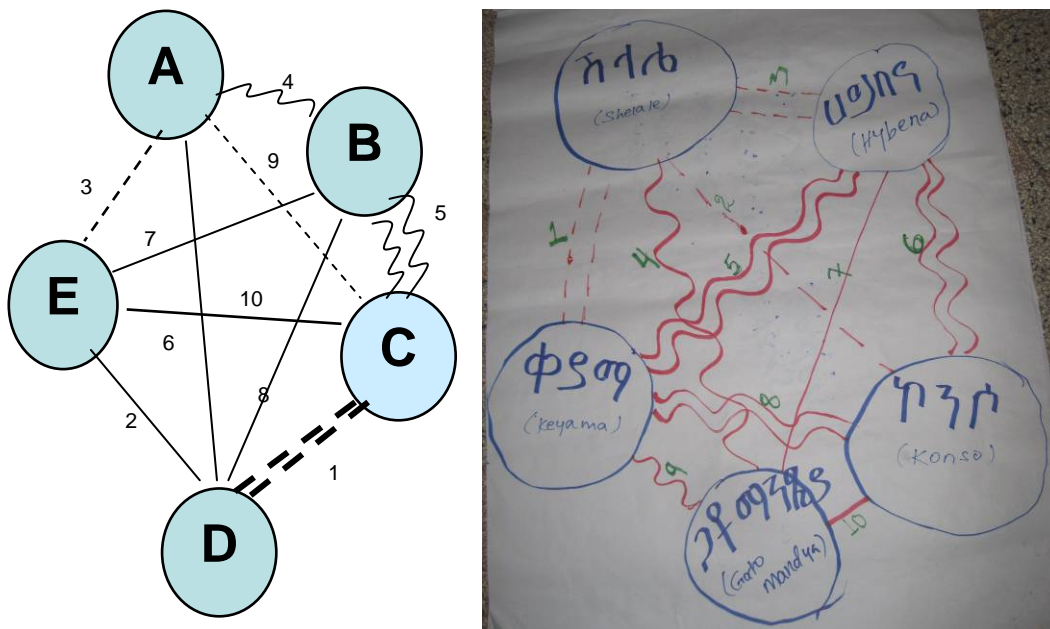

You should emphasize that the map is only a symbolic representation of how actors and groups are connected. Therefore it does not have to represent the geographic location of people, only how they are

related. Confirm with participants that the map is correct and that the lines accurately represent the relationships between key actors.

5. Describe the relationship between conflicting communities

You will ask a series of questions about Relationship #1, the relationship between the two conflicting communities. If there are three conflicting communities, then repeat the following series of questions for the relationship between Groups A and C.

Question 5a: Ask, “Why do you describe the relationship between your community and (conflicting community) Group B as good or bad?”

The note taker should listen and write down comments related to:

- How participants define a good or bad relationship;
- Types of activities that foster a positive or negative relationship (e.g., markets, shared religious institutions, work, other);
- Sources of tension (e.g., water, markets, roads, resources, aid, other);
- Recent events that illustrate that the relationship is good or bad.

Question 5b: Ask, “In the past 3 months, have there been any interactions between your community and (conflicting community) Group B? If so, what kinds of interactions?”

The purpose of this question is to explore both social and economic interactions between the key actors. The note taker should record this conversation carefully, noting both social and economic interactions as well as whether interactions are positive or negative. If the group has a hard time thinking of interactions, the facilitator can probe by asking about specific types of interactions.

Social interactions may include:

- going to the same church or mosque;
- attending the same social events such as marriages, funerals, celebrations, etc.;
- intermarriage;
- joint membership in community groups, etc.;
- going to the same school or health center.

Economic interactions may include:

- buying or selling goods to each other;
- frequenting the same markets;
- working for someone from the other community;
- employing a member of the other community, including to watch one’s animals or work in one’s field;
- giving or receiving a loan.

Question 5c: Ask, “Does your community see a benefit from interacting with (conflicting community) Group B?”

If the respondents answer yes, ask, “What type of benefits do you see from interacting with the conflicting community?” The note taker should write down all benefits that the community mentions, marking whether the benefit(s) are economic, political, social, or other.

If the group has mentioned economic benefits, ask, “How does your relationship with Group B benefit you economically?” If the group has not, explicitly ask, “Do you also benefit economically from your relationship with Group B? If so, how?”

Question 5d: Ask the group, “Among all possible benefits, which is the most important to you? Why?”

Question 5e: Ask, “Are there any formal economic associations between your community and (conflicting community) Group B? If so, what are they?”

Question 5f: Ask, “In the past 3 months, how often have your community and (conflicting community) Group B interacted *socially*: never, less than one time per month, one-two times per month, weekly, or daily?”

The note taker should use the following table to determine how to assign interaction scores to each relationship. These scores will be entered in the data entry form.

Frequency of Social Interaction between Conflicting Communities	Interaction Score
never	1
less than 1 time per month	2
1-2 times per month	3
weekly	4
daily	5

Question 5g: Ask, “In the past 3 months, how often have your community and (conflicting community) Group B interacted *economically*: never, less than one time per month, one-two times per month, weekly, or daily?”

The note taker should use the following table to determine how to assign interaction scores to each relationship. These scores will be entered in the data entry form.

Frequency of Economic Interaction between Conflicting Communities	Interaction Score
never	1
less than 1 time per month	2
1-2 times per month	3
weekly	4
daily	5

Question 5h: Ask, “If there is a dispute between people from your community and (conflicting community) Group B, how is that dispute usually handled?”

The note taker should use the following table to determine how to assign dispute resolution scores to each relationship. These scores will be entered in the data entry form.

Dispute Resolution Method	Dispute Resolution Score
Physical fighting	1
Verbal argument	2
Traditional mediation	3
Formal government mediation	4

Discussion and dialogue	5
-------------------------	---

Question 5i: Ask, “What would be needed to improve the relationship between your community and (conflicting community) Group B?” The note taker should take detailed notes about the response.

6. Describe relationships between other key actors

You will now ask a series of questions about the other relationships on the map (Relationships #2-10). Go through the entire series of questions for one relationship before moving on to the next, and repeat the series for each relationship until you have asked all questions for all relationships.

Question 6a: Ask, “Why do you describe the relationship between A and C as good or bad?”

The note taker should listen and write down comments related to:

- How participants define a good or bad relationship;
- Types of activities that foster a positive or negative relationship (e.g., markets, shared religious institutions, work, other);
- Sources of tension (e.g., water, markets, roads, resources, aid, other);
- Recent events that illustrate that the relationship is good or bad.

Question 6b: Ask, “In the past 3 months, have there been any interactions between A and C? If so, what kinds of interactions?”

The purpose of this question is to explore both social and economic interactions between the key actors. The note taker should record this conversation carefully, noting both social and economic interactions as well as whether interactions are positive or negative. If the group has a hard time thinking of interactions, the facilitator can probe by asking about specific types of interactions.

Social interactions may include:

- going to the same church or mosque;
- attending the same social events such as marriages, funerals, celebrations, etc.;
- intermarriage;
- joint membership in community groups, etc.;
- going to the same school or health center.

Economic interactions may include:

- buying or selling goods to each other;
- frequenting the same markets;
- working for someone from the other community;
- employing a member of the other community, including to watch one’s animals or work in one’s field;
- giving or receiving a loan.

Question 6c: Ask, “In the past 3 months, how often have A and C interacted in any way: never, less than one time per month, one-two times per month, weekly, or daily?” Please note that you are asking about the frequency in general, not disaggregating economic and social frequencies of interaction.

The note taker should use the following table to determine how to assign interaction scores to each relationship. These scores will be entered in the data entry form.

Frequency of Interaction	Interaction Score
--------------------------	-------------------

never	1
less than 1 time per month	2
1-2 times per month	3
weekly	4
daily	5

Question 6d: Ask, “If there is a dispute between people from A and C, how is that dispute usually handled?”

The note taker should use the following table to determine how to assign dispute resolution scores to each relationship. These scores will be entered in the data entry form.

Dispute Resolution Method	Dispute Resolution Score
Physical fighting	1
Verbal argument	2
Traditional mediation	3
Formal government mediation	4
Discussion and dialogue	5

Question 6e: If the relationship is bad or very bad, ask, “What would be needed to improve this relationship?” The note taker should take detailed notes about the response.

7. Conclusion

Thank the participants for their time and ask them whether they have any questions.

Take a picture of the map with a digital camera. Make sure that the information is legible.

Annex 8.10 Uganda/Ethiopia Disputes & Dispute Resolution

Participatory Assessment Tool: Disputes & Dispute Resolution

This tool was used in Uganda. A similar tool was used in Ethiopia.

Description

Participants identify the actors involved in local dispute resolution, identify common types of local disputes, and analyze how effective actors are in resolving local disputes. The tool combines open-ended discussion questions with several techniques for collecting quantitative data – including proportional piling, ranking, and scoring – in order to generate rich contextual data as well as benchmarks for monitoring and evaluation.

Objectives

- To identify the actors involved in local dispute resolution and evaluate how effective they are
- To identify common types of local conflict
- To establish benchmarks (e.g., baseline data) regarding the incidence of conflict and conflict resolution

Key Questions

- Who resolves disputes in the community?
- How effective are these actors at resolving disputes? Why?
- What types of conflict occur in the community?
- How frequently do these conflicts occur?
- Which types of conflict have the most negative impact on the community?
- Which types of conflict are most difficult to resolve? Why?
- How do community members define successful conflict resolution? How do community members define peace?

Key Indicators

- % decrease in reported incidents of violence
- % increase in peace agreements that are perceived as fair by parties
- % increase in peace agreements that have not been violated
- % change in satisfaction with local conflict resolution mechanisms
- % change in institutional conflict management capacity

Preparation

Make sure that you have all necessary materials. Arrange a meeting location with adequate space to facilitate the discussion where participants are unlikely to be disturbed by others.

Materials: flip chart, markers, about 150 counters (beans, stones, etc.), guide, data entry form, digital camera

Methodology

1. Introduction

Thank the participants for coming. Explain that you would like to understand how different people and institutions in the community resolve disputes.

2. List actors and institutions who resolve disputes

Ask the group to list actors and institutions who resolve disputes in their community. (You may need to have a brief discussion to come to a common understanding of the word “dispute,” but it should be understood broadly to encompass many kinds of conflict.) Explain that they can name types of people or institutions, whether traditional, official, formal, or informal. Write the list on a flip chart, using pictures to represent each actor. Ask the group to prioritize no more than 5 actors, and put a check mark beside those actors.

3. List the types of disputes

Next tell the group that you’d like to understand what types of disputes each of the actors/institutions resolves. Ask the group to list the types of dispute that occur in their community, including disputes between their own community and other communities. Write the list on the first flip chart, using pictures to represent each type of dispute. Once the group has listed the types of dispute, prioritize no more than 5 types of dispute.

Now draw the symbol representing each type of dispute that has been prioritized in a column on the left-hand side of a flip chart. Draw lines separating each type of dispute, so that you have several rows dividing the flip chart. Then draw each of the prioritized actor’s symbol across the horizontal top of a new flip chart. Draw lines separating each actor/institution, so that you have several columns dividing the flip chart.

At this point you will have a matrix that looks like this:

Disputes	Actor A	Actor B	Actor C	Actor D	Actor E
Type A					
Type B					
Type C					
Type D					
Type E					

4. Rank the frequency and impact of each type of dispute

- a. Tell the group you’d like to know which types of disputes occur most frequently. Give the group 20 counters (beans, stones, etc.). Ask them to allocate the counters between the various types of disputes. The greatest number of counters should be placed next to the most frequent type of dispute. An equal number of counters should be placed next to types of disputes that occur with the same frequency. Confirm that you understand the ranking from the most frequent to the least frequent type of dispute. The note taker should write down this ranking, with 1 being the most frequent type of dispute. The note taker should also write the number of counters assigned to each type of dispute.
- b. Ask the group to estimate the number of times each type of dispute occurred in the last 3 months.
- c. Remove the counters from the matrix, and tell the group you’d like to know which types of disputes impact their lives most negatively. Give the group the 20 counters again and ask them to allocate the counters between the various types of disputes. The greatest number of counters should be placed next to the type of dispute that has the most negative impact on their lives. An equal number of counters should be placed next to types of disputes that have an equal impact on their lives. Confirm that you understand the ranking from the type of dispute that has the most negative impact to the type of dispute that has the least negative impact. The note taker should write down this ranking,

with 1 being the type of dispute with the most negative impact. The note taker should also write the number of counters assigned to each type of dispute.

5. Determine who resolves each type of dispute and who is most successful

Tell the group that you'd like to understand who usually resolves the different types of disputes and how successful they are. For each type of dispute, give the group 20 counters and ask the following series of questions.

- a. Ask, "Who do people in your community usually go to in order to resolve this type of dispute?" Tell the group to place a counter in the column representing the actor or actors they go to in order to resolve that type of dispute.
- b. Using the remaining counters, ask the group to indicate which actors are most successful at resolving that type of dispute by allocating counters between the actors. The greatest number of counters should be placed in the column representing the actor who is most successful at resolving that type of dispute. Confirm that you understand the ranking of actors from the most to the least successful at resolving that type of dispute. The note taker should write down this ranking, with 1 being the actor who is most successful at resolving that type of dispute. The note taker should also write the number of counters assigned to each actor in that row.
- c. Ask, "How do you know that this type of dispute has been successfully resolved?" Probe on this question. For example, how does behavior change when a dispute has been resolved? What are people able to do once a dispute has been resolved that they may not have been able to do previously?
- d. Ask the group why they think the most successful actor at resolving that type of dispute is the most successful. Then ask the group why they think the least successful actor for resolving that dispute is the least successful.

Repeat this process for each type of dispute. Use a new set of 20 counters for each type of dispute.

6. Evaluate the success of dispute resolution mechanisms

Referring to the previous discussion, tell the group you'd like to understand who is overall most successful at resolving disputes. Give the group another 20 counters. Ask them to allocate the counters between the various actors, piling the counters next to the symbols on the flip chart representing each one. The greatest number of counters should be placed next to the actor that is most successful at dispute resolution. An equal number of counters should be placed next to actors that are equally successful at dispute resolution.

Once the piling is complete, ask the participants to explain it. Probe to understand why they consider some actors more successful than others at dispute resolution.

Confirm that you understand the ranking of actors from the most to the least successful at dispute resolution. The note taker should write down this ranking, with 1 being the actor who is overall most successful at resolving disputes. The note taker should also write the number of counters assigned to each actor in that row.

7. What prevents conflict from being resolved?

Referring to the previous discussion, ask the group which types of disputes are difficult to resolve. Identify the 3 types of disputes that are most difficult to resolve. Place a counter next to each of these types of disputes.

Ask them to explain why they think each of these types of disputes is difficult to resolve.

Ask them what needs to happen in order to promote the resolution of these types of disputes.

8. What is needed to stop cattle raiding?

Referring to the types of disputes that the group has named as difficult to resolve, explain that you would like to discuss cattle raiding in particular. Ask, “Why do people raid cattle?”

Then ask, “What is needed to stop cattle raiding? Do you think people will stop raiding cattle if they have other ways to earn a living? Why or why not?”

9. What are the limits to dispute resolution?

Explain that you’d like to understand if there are any limits to dispute resolution. Ask, “Are there situations where you think violence is justified? If so, what situations? Why?” Probe the group by asking follow-up questions such as, “What if your property is threatened?” or “What if you are pursuing your livelihood?” etc.

10. How do you know when there is peace?

Tell the group you realize that there are tensions between their community and some other communities. Ask the group how they will know when there is peace between these two conflicting communities and what the peace looks like. For example, how does behavior change when there is peace between the two communities? What are people able to do that they may not have been able to do previously?

11. Peace agreements

Ask whether any peace agreements between their community and the conflicting community have been put in place in the past year. If yes, ask the group the following 2 questions about each peace agreement put in place in the past year.

- a. Do you think the agreement is fair? Why?
- b. Has this agreement been violated? How? Why?

12. Conclusion

Thank the participants for their time and ask them whether they have any questions. Remind them that you will return to share the results of the focus group with them.

Annex 8.11 Ethiopia Internal Actor Mapping

Participatory Assessment Tool: Internal Actor Mapping

This tool was used in Ethiopia.

Description

Internal Actor Mapping identifies the actors from conflicting communities who both mitigate and aggravate the conflict and explores the reasons why they act the way they do. The tool combines open-ended discussion questions with several techniques for collecting quantitative data – including proportional piling, ranking, and scoring – in order to generate rich contextual data as well as benchmarks for monitoring and evaluation.

Objectives

- To identify the internal actors who both mitigate and aggravate a given conflict
- To explore the driving factors behind these actors' actions
- To explore the types of behavior that mitigate and aggravate conflict
- To establish benchmarks (e.g., baseline data) regarding the role of internal actors in conflict

Key Questions

- Who are the key actors in each community who both mitigate and aggravate conflict?
- What are the (perceived) motivations of these actors?
- Which internal actors have the greatest influence on the conflict?
- What is needed to stop certain actors from aggravating conflict? What might motivate these actors to become peace promoters?

Preparation

Make sure that you have all necessary materials. Arrange a meeting location with adequate space to facilitate the discussion where participants are unlikely to be disturbed by others. Given the potential sensitivity of this tool, invite participants who already know you and are comfortable with you. Participants may feel more comfortable discussing internal actors if they have already begun discussing the conflict in their community with you, perhaps through the use of one of the other tools such as Scored Community Relationship Mapping or Disputes & Dispute Resolution.

Materials: flip chart, markers, about 50 counters (stones, beans, etc.), guide, data entry form, digital camera

Time

2-3 hours

Methodology

1. Introduction

Thank the participants for coming. The note taker counts the number of participants, disaggregating by men, women, and male youth (ages 15-24).

Introduce yourself. Explain that due to Mercy Corps' previous work in the area, we understand that there is tension between the target community (the community you are conducting the focus group in) and another community. Specify the name of the community and confirm that this is correct. Explain that the purpose of the focus group is to understand the types of people and groups in each community who influence this relationship both positively and negatively. Clarify that you are not trying to identify specific individuals and that no one should mention any names. Remind the participants that there are no right or wrong responses; we are interested in their perception of the situation.

2. Internal actor mapping

Tell the group that you will discuss the institutions and groups in both their community and the conflicting community. Begin with the conflicting community, as participants may need to get comfortable with you before being willing to share information about people in their own community who may be involved in aggravating the conflict. Use a separate flip chart for each community, putting the name of the community at the top of each flip chart.

Brainstorm a list of internal actors: Ask the group to brainstorm a list of actors and groups who influence the relationship between the conflicting communities both positively and negatively. Clarify that you don't want the names of individuals but rather institutions or groups of people. Some groups might find it easier to list actors who promote peace first, and then discuss actors who aggravate the conflict.

Key actors might include:

- elders
- religious leaders
- kebele leaders
- youth
- women
- educated elites
- arms dealers
- traders and merchants
- ethnic groups or nationalities
- religious groups (e.g., Christians, Muslims, traditional religions)

The facilitator should ensure that both youth and women are listed, suggesting these two groups if the participants do not name them. The facilitator will record the suggested actors on an empty flip chart, drawing a symbol next to each actor so that the group can identify it. The note taker will make the same list in the notes.

Prioritize 5 key internal actors: After brainstorming, ask the participants to select 5 key actors who have the greatest influence, either positive or negative, on the conflict. Remind participants that the most relevant actors are not necessarily the most powerful or the ones with the most resources. Write the names and symbols of the 5 actors on the flip chart in a table like this:

Actor	Influence Score	Rank
Actor A		
Actor B		
Actor C		
Actor D		
Actor E		

For each of the 5 key actors, ask the following 4 questions. Ask all questions about a single actor before moving on to the next actors.

- Influence on the relationship: "How does this actor influence the relationship, either positively or negatively, between the conflicting communities?"
- Influence score: "Does the actor's actions make the relationship between the conflicting communities much better, a little better, worse, or much worse?" Use the following table to determine how to assign influence scores. Write the influence score in the "Influence" column on the flip chart.

Influence	Influence Score
much worse	-2
worse	-1
a little better	1
much better	2

- c. Perceived motivations: “Why does this actor act this way?” Continue asking “why?” until you fully understand the perceived motives of the actor.
- d. Needed changes: (if the impact score is negative) “What needs to change or happen so that this actor no longer negatively influences the relationship and promotes peace?”

Repeat these 4 questions for each actor.

Proportional piling: Once all 5 actors have been discussed, ask the participants to rank the actors according to their influence on the relationship between the conflicting communities. Give the group 20 counters (beans, stones, etc.) and ask them to allocate the counters between the 5 actors, piling the counters next to the symbols on the flip chart representing each of the 5 actors in the “Rank” column. The greatest number of counters should be placed next to the actor with the most **positive** influence on the relationship between the conflicting communities. An equal number of counters should be placed next to actors that have a similar influence on the relationship between the conflicting communities. Once the piling is complete, ask the participants to explain it. Confirm that you understand the ranking of actors from the most positive to the most negative influence on the conflict.

The note taker will copy the table in the notes and will write down the number of counters placed next to each actor. The note taker should rank the actors from 1 to 5, with 5 indicating the actor with the most positive influence on the relationship between the conflicting communities (e.g., the actor who promotes peace the most) and 1 being the actor with the most negative influence on the relationship between the conflicting communities (e.g., the actor who aggravates conflict the most).

3. Conclusion

Thank the participants for their time and ask them whether they have any questions.

Take a picture of the table with a digital camera. Make sure that the information is legible.

Annex 8.12 Violent Incident Reporting Form

Name of person reporting data: _____ District Peace Committee:
Contact information: _____ Sub-county Peace Committee:
 Parish Peace Committee:
 Joint Monitoring Team:

1. When did the incident occur?

Date incident occurred: _____ Time incident occurred: _____

2. Where did the incident occur?

Describe exact location: _____
Village: _____ Sub-county: _____
Parish: _____ District: _____

3. What type of incident occurred? (Check all that apply)

Beating Abduction
 Killing Household theft
 Cattle raid Domestic violence
 Ambush Rape or defilement
 Other (specify) _____

4. What were the consequences of this incident? (Check all that apply)

Death Material damage or loss
 Serious injury (hospital care or healer) Displacement
 Minor injury Nothing
 Other (specify) _____

5. How many people were involved in the incident?

Estimated number of victims: _____ Estimated number of perpetrators: _____

6. Who was involved in the incident? (Check all that apply)

Estimated number of victims: _____ Estimated number of perpetrators: _____
 Acholi Youth/karachuna
 Dodoth Women
 Jie Security forces (specify) _____
 Other tribe (specify) _____ Other (specify) _____
 Unknown tribe

7. Briefly describe what happened on the other side of this paper.

8. What was the conflict about? _____

9. Was this incident:

an isolated incident (does not take place often) a recurrent incident (takes place often)

10. How wide-spread was the violence?

Limited to initial location Spread to other areas (specify): _____

11. What did the Peace Committee do in response to this incident? _____

12. Name and signature of at least two Peace Committee members:

Annex 8.13 Dispute Resolution Reporting Form

Award # 617-A-00-09-00008-00	Uganda Building Bridges to Peace
------------------------------	----------------------------------

Dispute Resolution Reporting Form

PART I: Basic Information

<table border="1" style="width: 100%; border-collapse: collapse;"> <tr><td style="width: 80%;">1. Agreement Number</td><td style="width: 20%;"></td></tr> <tr><td>2. Negotiator / Negotiating Body</td><td></td></tr> <tr><td>3. Mercy Corps Focal Point</td><td></td></tr> <tr><td>4. Negotiation Start Date</td><td></td></tr> <tr><td>5. Negotiation End Date</td><td></td></tr> <tr><td>6. Status</td><td></td></tr> <tr><td>7. Length of Agreement</td><td></td></tr> <tr><td>8. Today's Date OR Agreement End Date</td><td></td></tr> </table>	1. Agreement Number		2. Negotiator / Negotiating Body		3. Mercy Corps Focal Point		4. Negotiation Start Date		5. Negotiation End Date		6. Status		7. Length of Agreement		8. Today's Date OR Agreement End Date		<table border="1" style="width: 100%; border-collapse: collapse;"> <tr> <td style="width: 60%;">11. Beneficiaries</td> <td style="width: 20%;">Direct</td> <td style="width: 20%;">Indirect</td> </tr> <tr> <td style="text-align: right;">Female</td> <td></td> <td></td> </tr> <tr> <td style="text-align: right;">Male</td> <td></td> <td></td> </tr> <tr><td>12. District</td><td colspan="2"></td></tr> <tr><td>13. Village</td><td colspan="2"></td></tr> <tr><td>14. Primary Dispute Type</td><td colspan="2"></td></tr> <tr><td>15. Secondary Dispute Type</td><td colspan="2"></td></tr> <tr><td>16. Match</td><td colspan="2"></td></tr> </table>	11. Beneficiaries	Direct	Indirect	Female			Male			12. District			13. Village			14. Primary Dispute Type			15. Secondary Dispute Type			16. Match		
1. Agreement Number																																									
2. Negotiator / Negotiating Body																																									
3. Mercy Corps Focal Point																																									
4. Negotiation Start Date																																									
5. Negotiation End Date																																									
6. Status																																									
7. Length of Agreement																																									
8. Today's Date OR Agreement End Date																																									
11. Beneficiaries	Direct	Indirect																																							
Female																																									
Male																																									
12. District																																									
13. Village																																									
14. Primary Dispute Type																																									
15. Secondary Dispute Type																																									
16. Match																																									

9. Number of violent incidents before agreement	
10. Number of violent incidents after agreement	

17. PART II: Brief Description of Dispute/Conflict
 Please provide a concise, clear background of the conflict/problem. WHO are the primary actors involved in this conflict? WHAT is the problem between the parties? HOW did the problem start/escalate? WHY has the problem not yet been resolved?

18. PART III: Dispute Resolution

Who were the actors (individuals and/or agencies) involved in resolving the dispute?

What process did these actors follow to resolve the dispute? What was the dispute resolution process?

Was the dispute resolved successfully? Why or why not?

Please provide detailed information on the agreement reached.

Other comments and lessons learned.

19. PART IV: Internal Management

Collected by:		Date:	
Reviewed/approved by:		Date:	
Copy received for M&E by:		Date:	
Data entered electronically by:		Date:	

Annex 8.14 Selected References

Designing for Results: Integrating Monitoring and Evaluation in Conflict Transformation Programs. Cheyanne Church and Mark M. Rogers. Search for Common Ground, 2006.

http://www.sfcg.org/programmes/ilr/ilt_manualpage.html

Guidance on Evaluating Conflict Prevention and Peacebuilding Activities: Working Draft for Application Period. OECD Development Assistance Committee, 2008.

http://www.oecd.org/secure/pdfDocument/0,2834,en_21571361_34047972_39774574_1_1_1_1,00.pdf

Participatory Impact Assessment: A Guide for Practitioners. Andrew Catley, John Burns, Dawit Abebe, and Omeno Suji. Tufts University Feinstein International Center, 2008.

<https://wikis.uit.tufts.edu/confluence/display/FIC/Participatory+Impact+Assessment>

Reflective Peacebuilding: A Planning, Monitoring and Learning Toolkit. Hal Culbertson, John Paul Lederach, and Reina Neufeldt. The Joan B. Kroc Institute for International Peace Studies and Catholic Relief Services, Southeast East Asia Regional Office, 2007.

http://www.nd.edu/~krocinst/documents/crs_reflective_final.pdf

Global Headquarters

Mercy Corps
45 SW Ankeny Street
Portland, Oregon, 97204
800.292.3355
www.mercycorps.org